

09/08/2023

**TIP PROJECT: W-570IH**

**CONTRACT: DA00566**

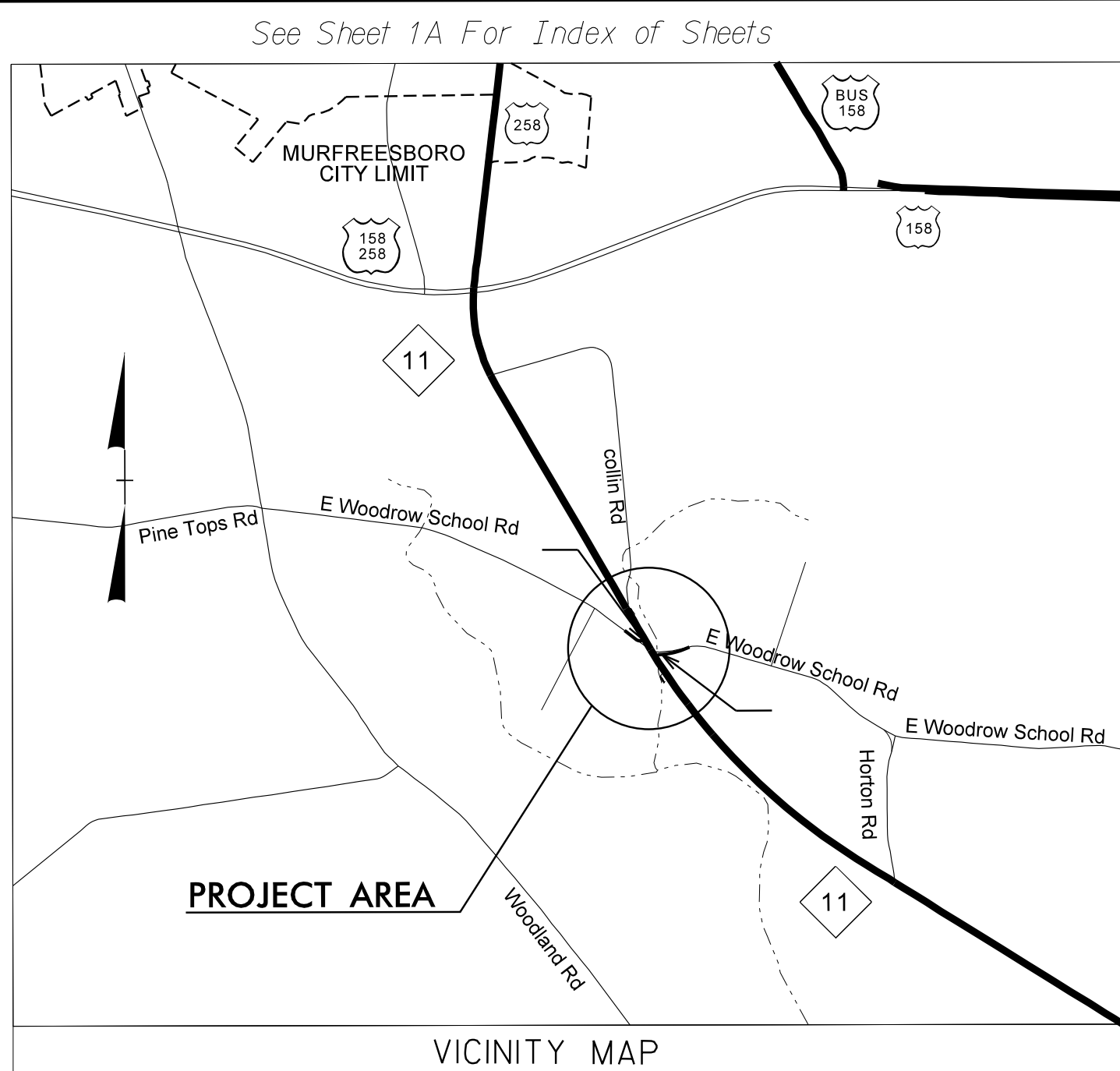

STATE OF NORTH CAROLINA  
DIVISION OF HIGHWAYS  
**HERTFORD COUNTY**

**LOCATION: NC 11 INTERSECTION AT SR 1169 (E WOODROW SCHOOL RD)**

**TYPE OF WORK: GRADING, DRAINAGE AND PAVING**

STATE	STATE PROJECT REFERENCE NO.	SHEET NO.	TOTAL SHEETS
N.C.	W-570IH	1	
STATE PROJ. NO.	F.A. PROJ. NO.	DESCRIPTION	
44847.1.8	HSIP-001(043)	PE	
44847.2.8		RW	
44847.3.8		CONST.	

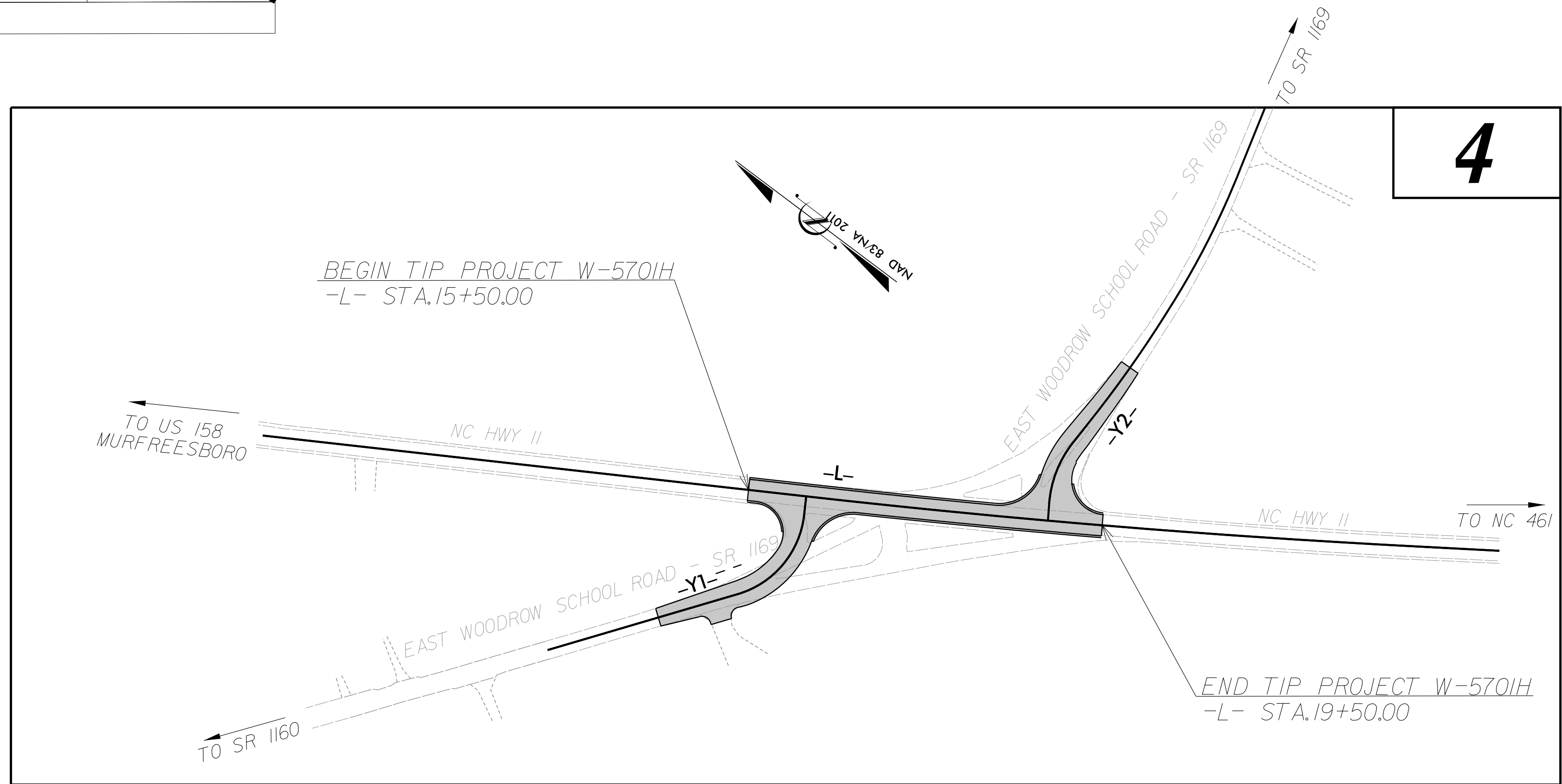

**4**

**V&M**  
**Vaughn & Melton**  
Consulting Engineers

Asheville, North Carolina  
828-253-2796

- Boone, NC 828-355-9933
- Tri-Cities, TN 423-467-8401
- Knoxville, TN 865-546-5800
- Spartanburg, SC 864-574-4775
- Charleston, SC 843-974-5650
- Middlesboro, KY 606-248-6600
- Raleigh, NC 919-977-9455
- Charlotte, NC 704-357-0488
- Atlanta, GA 770-627-3509

Copyright © 2006 Vaughn & Melton, Inc. All Rights Reserved

**DOCUMENT NOT CONSIDERED FINAL UNLESS ALL SIGNATURES COMPLETED**

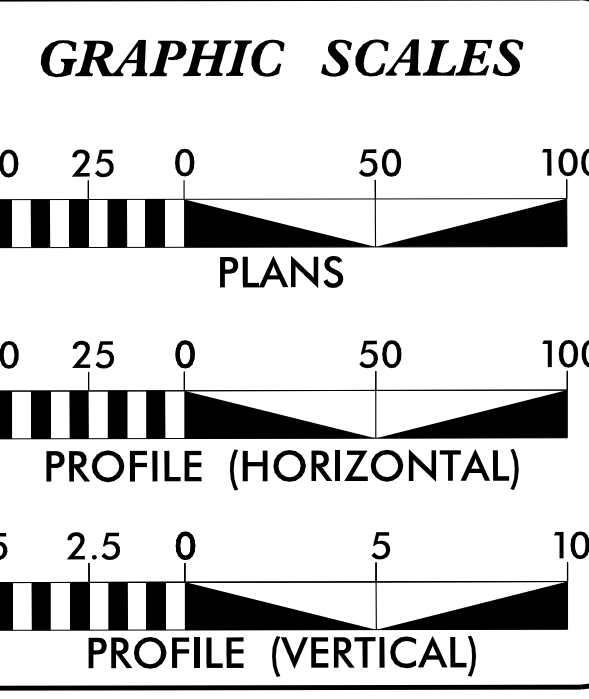

**DESIGN DATA**  
ADT 2020 = 4100

V = 60 MPH  
\* TTST = 3% DUAL 4%  
FUNC CLASS = MAJOR COLLECTOR  
TIER REGIONAL

**PROJECT LENGTH**

LENGTH ROADWAY PROJECT = 0.076 MI  
TOTAL LENGTH PROJECT = 0.076 MI

Prepared in the Office of:  
**VAUGHN & MELTON**  
1318-F PATTON AVE., Asheville NC, 28806

2018 STANDARD SPECIFICATIONS

**RIGHT OF WAY DATE:** September 14, 2022

**LETTING DATE:**

**JOHN LANSFORD, PE**  
PROJECT ENGINEER

**ALEX FITZPATRICK**  
PROJECT DESIGN ENGINEER

**HYDRAULICS ENGINEER**

DocuSigned by:  
*John Lansford*  
AB50F2E27A0C43C...  
SIGNATURE:

**ROADWAY DESIGN ENGINEER**

DocuSigned by:  
*John Lansford*  
F5B70E2FB8A54D4...  
SIGNATURE:

Professional Engineer Seal for John C. Lansford, No. 047435, State of North Carolina, expires 5/31/2023.

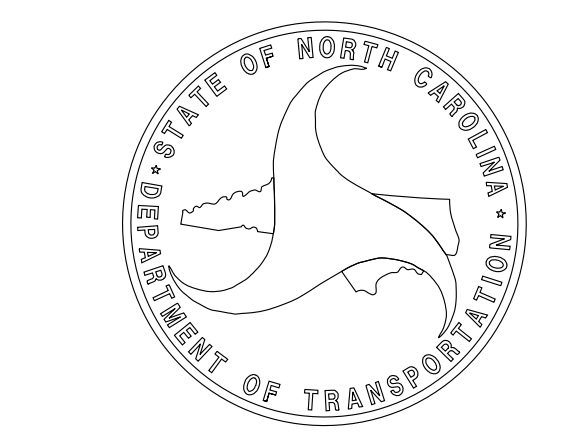

5/14/99

PROJECT REFERENCE NO.	SHEET NO.
W-5701H	1A
RW SHEET NO.	
ROADWAY DESIGN ENGINEER	

**DOCUMENT NOT CONSIDERED FINAL UNLESS ALL SIGNATURES COMPLETED**

INDEX OF SHEETS

SHEET NUMBER	SHEET
1	TITLE SHEET
1A	INDEX OF SHEETS, GENERAL NOTES, AND STANDARD DRAWINGS
1B	CONVENTIONAL SYMBOLS
2A-1 THRU 2A-2	TYPICAL SECTIONS
3B-1	SUMMARY OF EARTHWORK AND PAVEMENT REMOVAL
3D-1	DRAINAGE SUMMARY
4	PLAN SHEET
5	PROFILE SHEET
RW-1 THRU RW-2	RIGHT OF WAY SHEETS
TMP-1 THRU TMP-4	TRAFFIC MANAGEMENT PLANS
PMP-1 THRU PMP-2	PAVEMENT MARKING PLANS
EC-1 THRU EC-5	EROSION CONTROL PLANS
SIGN-1 THRU SIGN-4	SIGNING PLANS
X-1	CROSS SECTION INDEX
X-1A	CROSS SECTION SUMMARY
X-2 THRU X-7	CROSS SECTIONS

GENERAL NOTES: 2018 SPECIFICATIONS  
EFFECTIVE: 01-16-2018  
REVISED:

GRADING AND SURFACING OR RESURFACING AND WIDENING:  
THE GRADE LINES SHOWN DENOTE THE FINISHED ELEVATION OF THE PROPOSED SURFACING AT GRADE POINTS SHOWN ON THE TYPICAL SECTIONS. WHERE NO GRADE LINES ARE SHOWN, THE PROFILES SHOWN DENOTE THE TOP ELEVATION OF THE EXISTING PAVEMENT ALONG THE CENTER LINE OF SURVEY ON WHICH THE PROPOSED RESURFACING WILL BE PLACED. GRADE LINES MAY BE ADJUSTED BY THE ENGINEER IN ORDER TO SECURE A PROPER TIE-IN.

CLEARING:  
CLEARING ON THIS PROJECT SHALL BE PERFORMED TO THE LIMITS ESTABLISHED BY METHOD II.

SUPERELEVATION:  
ALL CURVES ON THIS PROJECT SHALL BE SUPERELEVATED IN ACCORDANCE WITH STD. NO. 225.05 USING THE RATE OF SUPERELEVATION AND RUNOFF SHOWN ON THE PLANS. SUPERELEVATION IS TO BE REVOLVED ABOUT THE GRADE POINTS SHOWN ON THE TYPICAL SECTIONS.

SIDE ROADS:  
THE CONTRACTOR WILL BE REQUIRED TO DO ALL NECESSARY WORK TO PROVIDE SUITABLE CONNECTIONS WITH ALL ROADS, STREETS, AND DRIVES ENTERING THIS PROJECT. THIS WORK WILL BE PAID FOR AT THE CONTRACT UNIT PRICE FOR THE PARTICULAR ITEMS INVOLVED.

UTILITIES:  
UTILITY OWNERS ON THIS PROJECT ARE CENTURY LINK, TIME WARNER, MCNC, AND ROANOKE ELECTRIC.  
ANY RELOCATION OF EXISTING UTILITIES WILL BE ACCOMPLISHED BY OTHERS, EXCEPT AS SHOWN ON THE PLANS.

EFF. 01-16-2018  
REV.

2018 ROADWAY ENGLISH STANDARD DRAWINGS

The following Roadway Standards as appear in "Roadway Standard Drawings" Highway Design Branch - N. C. Department of Transportation - Raleigh, N. C., Dated January, 2018 are applicable to this project and by reference hereby are considered a part of these plans:

STD.NO.	TITLE
DIVISION 2 - EARTHWORK	
200.02	Method of Clearing - Method II
225.02	Guide for Grading Subgrade - Secondary and Local
225.04	Method of Obtaining Superelevation - Two Lane Pavement
DIVISION 3 - PIPE CULVERTS	
300.01	Method of Pipe Installation
310.10	Driveway Pipe Construction
DIVISION 5 - SUBGRADE, BASES AND SHOULDERS	
560.01	Method of Shoulder Construction - High Side of Superelevated Curve - Method I
DIVISION 6 - ASPHALT BASES AND PAVEMENTS	
654.01	Pavement Repairs

5/2/2023 4:50:00 AM  
User: jlangston

# STATE OF NORTH CAROLINA, DIVISION OF HIGHWAYS CONVENTIONAL PLAN SHEET SYMBOLS

*Note: Not to Scale*

### BOUNDARIES AND PROPERTY:

State Line	-----	
County Line	-----	
Township Line	-----	
City Line	-----	
Reservation Line	-----	
Property Line	-----	
Existing Iron Pin (EIP)	-----	⊙
Computed Property Corner	-----	X
Existing Concrete Monument (ECM)	-----	⊠
Parcel / Sequence Number	-----	(23)
Existing Fence Line	-x-x-x-	
Proposed Woven Wire Fence	-----	○
Proposed Chain Link Fence	-----	⊠
Proposed Barbed Wire Fence	-----	◇
Existing Wetland Boundary	-----	MLB
Proposed Wetland Boundary	-----	MLB
Existing Endangered Animal Boundary	-----	EAB
Existing Endangered Plant Boundary	-----	EPB
Existing Historic Property Boundary	-----	HPB
Known Contamination Area: Soil	-----	
Potential Contamination Area: Soil	-----	
Known Contamination Area: Water	-----	
Potential Contamination Area: Water	-----	
Contaminated Site: Known or Potential	-----	☠ ☢

### BUILDINGS AND OTHER CULTURE:

Gas Pump Vent or U/G Tank Cap	-----	○
Sign	-----	⊙
Well	-----	⊙
Small Mine	-----	⊗
Foundation	-----	⊠
Area Outline	-----	⊠
Cemetery	-----	⊠
Building	-----	⊠
School	-----	⊠
Church	-----	⊠
Dam	-----	-----

### HYDROLOGY:

Stream or Body of Water	-----	
Hydro, Pool or Reservoir	-----	
Jurisdictional Stream	-----	JS
Buffer Zone 1	-----	BZ 1
Buffer Zone 2	-----	BZ 2
Flow Arrow	-----	←
Disappearing Stream	-----	→
Spring	-----	⊙
Wetland	-----	⊙
Proposed Lateral, Tail, Head Ditch	-----	-----
False Sump	-----	-----

### RAILROADS:

Standard Gauge	-----	CSX TRANSPORTATION
RR Signal Milepost	-----	MILEPOST 35
Switch	-----	SWITCH
RR Abandoned	-----	-----
RR Dismantled	-----	-----

### RIGHT OF WAY & PROJECT CONTROL:

Primary Horiz Control Point	-----	⬡
Primary Horiz and Vert Control Point	-----	⬢
Secondary Horiz and Vert Control Point	-----	⬢
Vertical Benchmark	-----	⊠
Existing Right of Way Monument	-----	⬡
Proposed Right of Way Monument (Rebar and Cap)	-----	▲
Proposed Right of Way Monument (Concrete)	-----	⬢
Existing Permanent Easement Monument	-----	◇
Proposed Permanent Easement Monument (Rebar and Cap)	-----	⬢
Existing C/A Monument	-----	▲
Proposed C/A Monument (Rebar and Cap)	-----	▲
Proposed C/A Monument (Concrete)	-----	⬢
Existing Right of Way Line	-----	-----
Proposed Right of Way Line	-----	⊠
Existing Control of Access Line	-----	⊠
Proposed Control of Access Line	-----	⊠
Proposed ROW and CA Line	-----	⊠
Existing Easement Line	-----	E
Proposed Temporary Construction Easement	-----	E
Proposed Temporary Drainage Easement	-----	TDE
Proposed Permanent Drainage Easement	-----	PDE
Proposed Permanent Drainage/Utility Easement	-----	DUE
Proposed Permanent Utility Easement	-----	PUE
Proposed Temporary Utility Easement	-----	TUE
Proposed Aerial Utility Easement	-----	AUE

### ROADS AND RELATED FEATURES:

Existing Edge of Pavement	-----	-----
Existing Curb	-----	-----
Proposed Slope Stakes Cut	-----	C
Proposed Slope Stakes Fill	-----	F
Proposed Curb Ramp	-----	CR
Existing Metal Guardrail	-----	-----
Proposed Guardrail	-----	-----
Existing Cable Guiderail	-----	-----
Proposed Cable Guiderail	-----	-----
Equality Symbol	-----	⊕
Pavement Removal	-----	-----

### VEGETATION:

Single Tree	-----	⊙
Single Shrub	-----	⊙
Hedge	-----	-----

Woods Line	-----	-----
Orchard	-----	-----
Vineyard	-----	Vineyard

### EXISTING STRUCTURES:

MAJOR:		
Bridge, Tunnel or Box Culvert	-----	CONC
Bridge Wing Wall, Head Wall and End Wall	-----	CONC WW
MINOR:		
Head and End Wall	-----	CONC HW
Pipe Culvert	-----	-----
Footbridge	-----	-----
Drainage Box: Catch Basin, DI or JB	-----	CB
Paved Ditch Gutter	-----	-----
Storm Sewer Manhole	-----	⊙
Storm Sewer	-----	S

### UTILITIES:

\* SUE - Subsurface Utility Engineering  
LOS - Level of Service - A,B,C or D (Accuracy)

#### POWER:

Existing Power Pole	-----	⊙
Proposed Power Pole	-----	⊙
Existing Joint Use Pole	-----	⊙
Proposed Joint Use Pole	-----	⊙
Power Manhole	-----	⊙
Power Line Tower	-----	⊠
Power Transformer	-----	⊠
U/G Power Cable Hand Hole	-----	⊠
H-Frame Pole	-----	⊙
U/G Power Line Test Hole (SUE - LOS A)*	-----	⊙
U/G Power Line (SUE - LOS B)*	-----	P
U/G Power Line (SUE - LOS C)*	-----	P
U/G Power Line (SUE - LOS D)*	-----	P

#### TELEPHONE:

Existing Telephone Pole	-----	⊙
Proposed Telephone Pole	-----	⊙
Telephone Manhole	-----	⊙
Telephone Pedestal	-----	⊠
Telephone Cell Tower	-----	⊠
U/G Telephone Cable Hand Hole	-----	⊠
U/G Telephone Test Hole (SUE - LOS A)*	-----	⊙
U/G Telephone Cable (SUE - LOS B)*	-----	T
U/G Telephone Cable (SUE - LOS C)*	-----	T
U/G Telephone Cable (SUE - LOS D)*	-----	T
U/G Telephone Conduit (SUE - LOS B)*	-----	Tc
U/G Telephone Conduit (SUE - LOS C)*	-----	Tc
U/G Telephone Conduit (SUE - LOS D)*	-----	Tc
U/G Fiber Optics Cable (SUE - LOS B)*	-----	T fo
U/G Fiber Optics Cable (SUE - LOS C)*	-----	T fo
U/G Fiber Optics Cable (SUE - LOS D)*	-----	T fo

### WATER:

Water Manhole	-----	⊙
Water Meter	-----	⊙
Water Valve	-----	⊙
Water Hydrant	-----	⊙
U/G Water Line Test Hole (SUE - LOS A)*	-----	⊙
U/G Water Line (SUE - LOS B)*	-----	W
U/G Water Line (SUE - LOS C)*	-----	W
U/G Water Line (SUE - LOS D)*	-----	W
Above Ground Water Line	-----	A/G Water

### TV:

TV Pedestal	-----	⊠
TV Tower	-----	⊠
U/G TV Cable Hand Hole	-----	⊠
U/G TV Test Hole (SUE - LOS A)*	-----	⊙
U/G TV Cable (SUE - LOS B)*	-----	TV
U/G TV Cable (SUE - LOS C)*	-----	TV
U/G TV Cable (SUE - LOS D)*	-----	TV
U/G Fiber Optic Cable (SUE - LOS B)*	-----	TV fo
U/G Fiber Optic Cable (SUE - LOS C)*	-----	TV fo
U/G Fiber Optic Cable (SUE - LOS D)*	-----	TV fo

### GAS:

Gas Valve	-----	◇
Gas Meter	-----	⊙
U/G Gas Line Test Hole (SUE - LOS A)*	-----	⊙
U/G Gas Line (SUE - LOS B)*	-----	G
U/G Gas Line (SUE - LOS C)*	-----	G
U/G Gas Line (SUE - LOS D)*	-----	G
Above Ground Gas Line	-----	A/G Gas

### SANITARY SEWER:

Sanitary Sewer Manhole	-----	⊙
Sanitary Sewer Cleanout	-----	⊙
U/G Sanitary Sewer Line	-----	SS
Above Ground Sanitary Sewer	-----	A/G Sanitary Sewer
SS Force Main Line Test Hole (SUE - LOS A)*	-----	⊙
SS Force Main Line (SUE - LOS B)*	-----	FSS
SS Force Main Line (SUE - LOS C)*	-----	FSS
SS Force Main Line (SUE - LOS D)*	-----	FSS

### MISCELLANEOUS:

Utility Pole	-----	⊙
Utility Pole with Base	-----	⊠
Utility Located Object	-----	⊙
Utility Traffic Signal Box	-----	⊠
Utility Unknown U/G Line (SUE - LOS B)*	-----	UUL
U/G Tank; Water, Gas, Oil	-----	⊠
Underground Storage Tank, Approx. Loc.	-----	UST
A/G Tank; Water, Gas, Oil	-----	⊠
Geoenvironmental Boring	-----	⊙
Abandoned According to Utility Records	-----	AATUR
End of Information	-----	E.O.I.



PROJECT REFERENCE NO. W-5701H	SHEET NO. 2A-1
RW SHEET NO.	
ROADWAY DESIGN ENGINEER	
DOCUMENT NOT CONSIDERED FINAL UNLESS ALL SIGNATURES COMPLETED	

PAVEMENT SCHEDULE	
C1	PROP. 3" ASPHALT CONCRETE SURFACE COURSE, TYPE S9.5B, AT AN AVERAGE RATE OF 165 LBS. PER SQ. YD. IN EACH OF TWO LAYERS
C2	PROP. VAR. DEPTH ASPHALT CONCRETE SURFACE COURSE, TYPE S9.5B, AT AN AVERAGE RATE OF 110 LBS. PER SQ. YD. PER 1" DEPTH. TO BE PLACED IN LAYERS NOT TO EXCEED 3" IN DEPTH.
E1	PROP. APPROX. 11" ASPHALT CONCRETE BASE COURSE TYPE B25.0C, AT AN AVERAGE RATE OF 627 LBS. PER SQ. YD. IN EACH OF TWO LAYERS
E2	PROP. VAR. DEPTH ASPHALT CONCRETE BASE COURSE, TYPE B25.0C, AT AN AVERAGE RATE OF 114 LBS. PER SQ. YD. PER 1" DEPTH. TO BE PLACED IN LAYERS NOT LESS THAN 3" IN DEPTH OR GREATER THAN 5 1/2" IN DEPTH.
T	EARTH MATERIAL
U	EXISTING PAVEMENT
V	MILLING BITUMINOUS PAVEMENT. 3" DEPTH.
W	VARIABLE DEPTH ASPHALT PAVEMENT

NOTE: PAVEMENT EDGE SLOPES ARE 1:1 UNLESS SHOWN OTHERWISE.

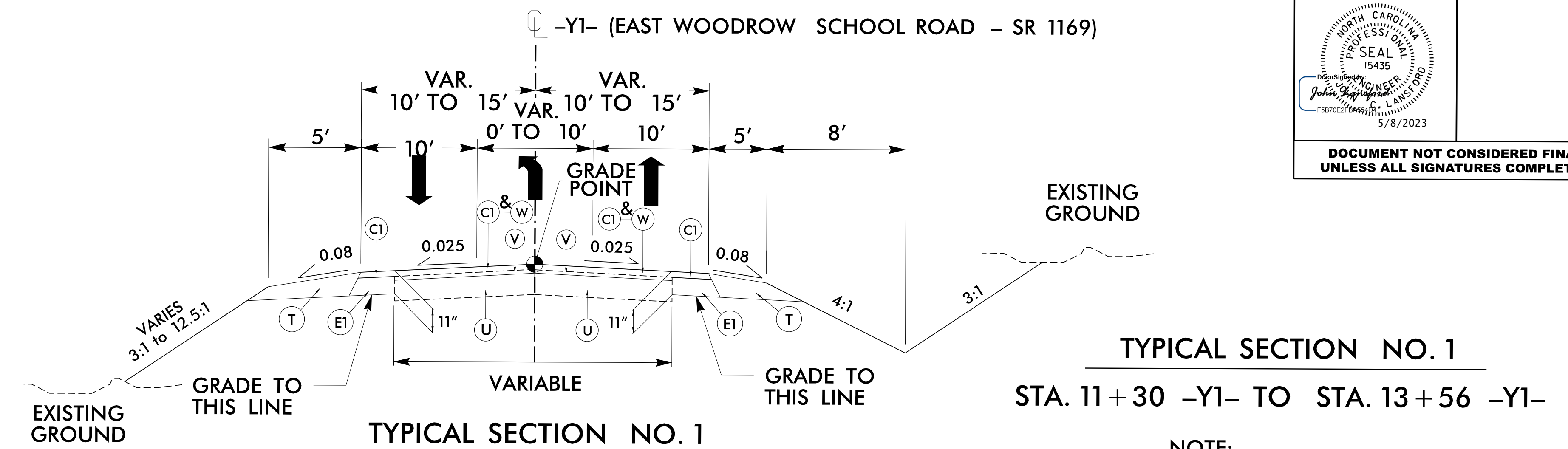

- NOTE:
1. TRENCH, GRADE AND PLACE E1 TO EXISTING PAVEMENT ELEVATION
  2. MILL 3" ACROSS ENTIRE PROPOSED WIDTH
  3. PLACE FINAL PAVEMENT COURSES (WEDGING AND C1)

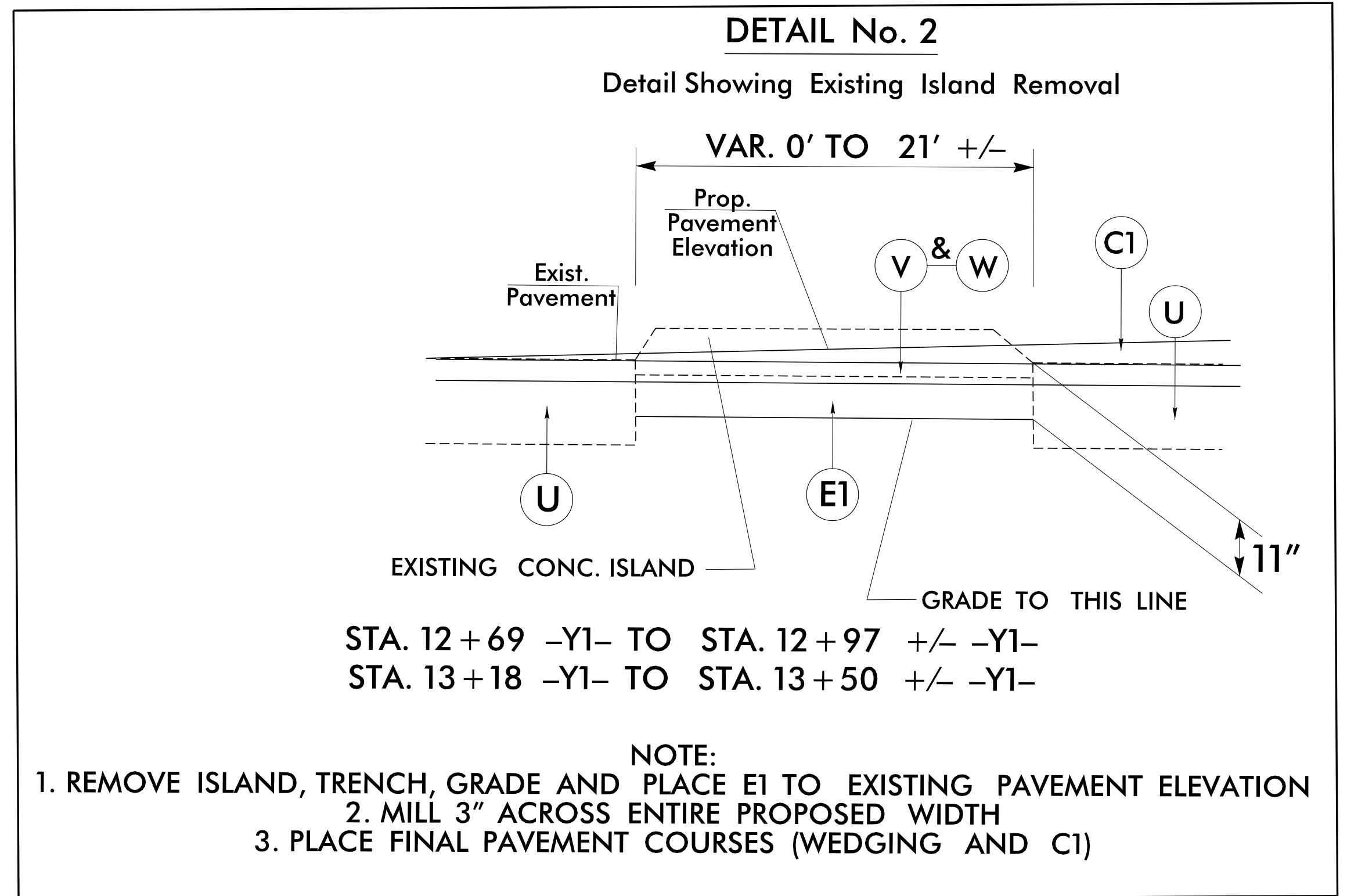
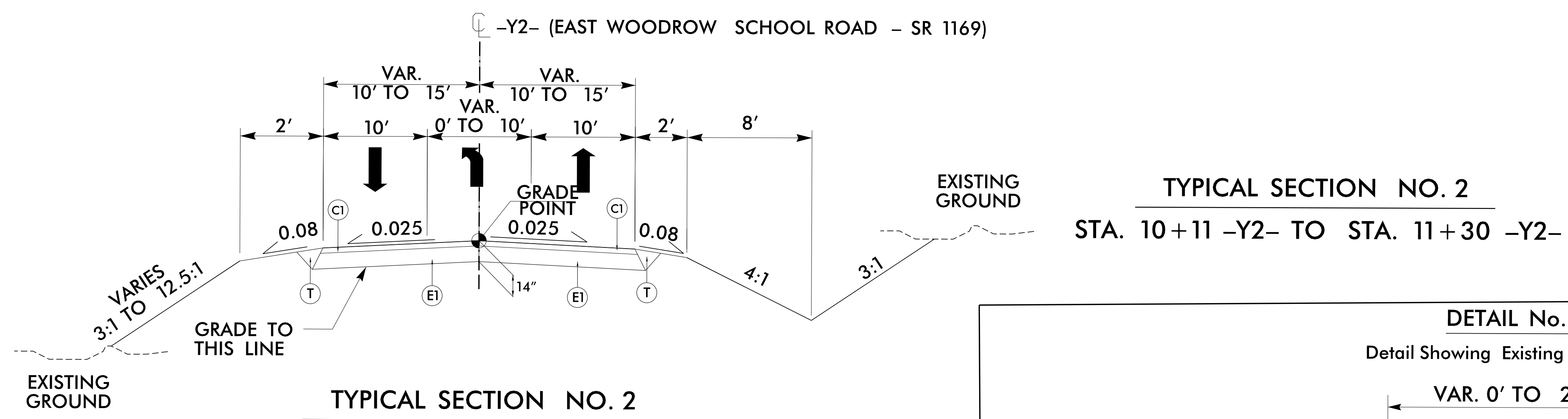

- NOTE:
1. REMOVE ISLAND, TRENCH, GRADE AND PLACE E1 TO EXISTING PAVEMENT ELEVATION
  2. MILL 3" ACROSS ENTIRE PROPOSED WIDTH
  3. PLACE FINAL PAVEMENT COURSES (WEDGING AND C1)

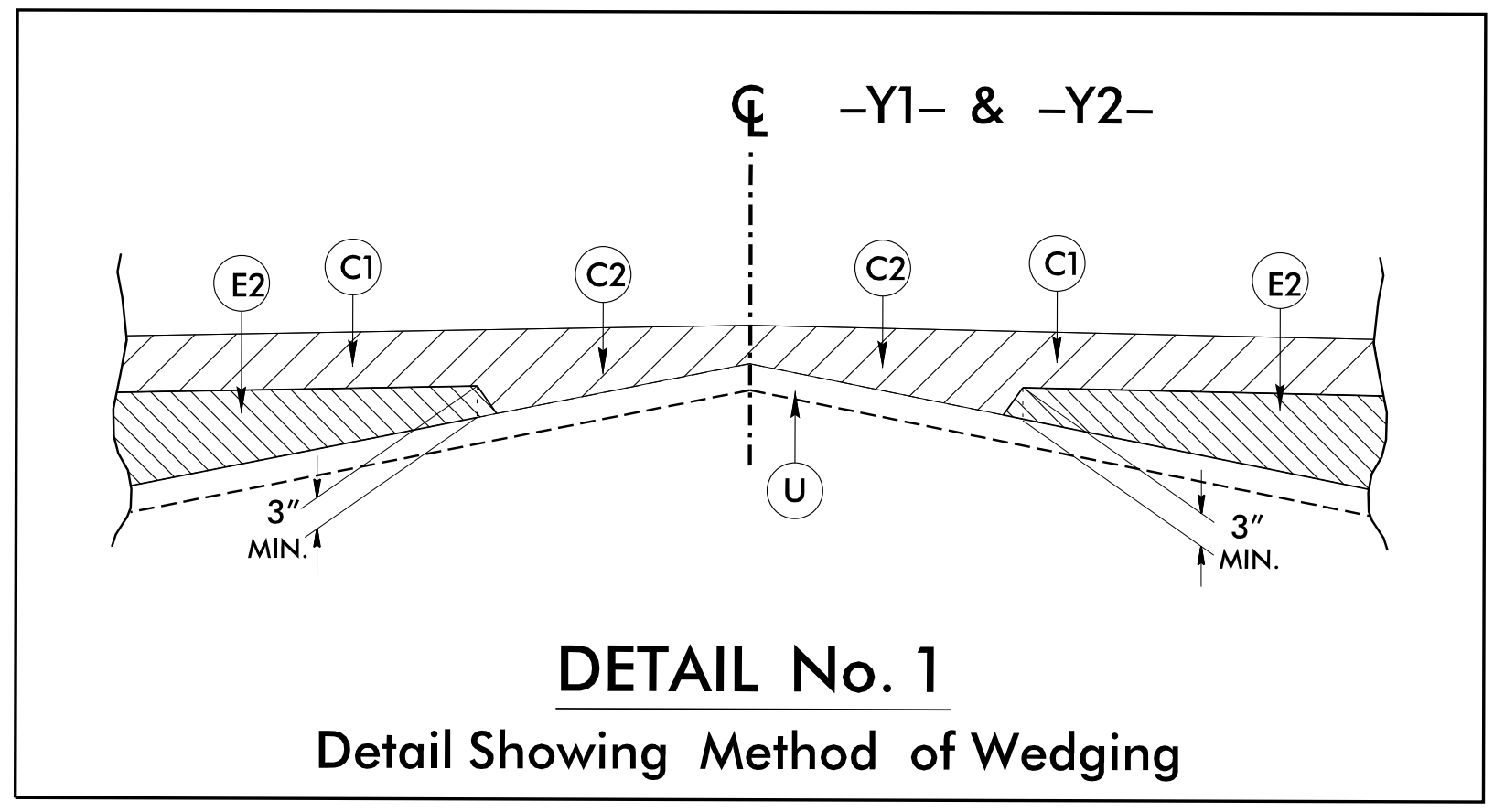

5/14/23

5/15/2023 11:44:04 AM  
I:\Projects\W-5701H-rdy-tyj\p.dgn

5/14/23

PROJECT REFERENCE NO. W-5701H	SHEET NO. 2A-2
R/W SHEET NO.	
ROADWAY DESIGN ENGINEER	
DOCUMENT NOT CONSIDERED FINAL UNLESS ALL SIGNATURES COMPLETED	

PAVEMENT SCHEDULE	
C1	PROP. 3" ASPHALT CONCRETE SURFACE COURSE, TYPE S9.5B, AT AN AVERAGE RATE OF 165 LBS. PER SQ. YD. IN EACH OF TWO LAYERS
C2	PROP. VAR. DEPTH ASPHALT CONCRETE SURFACE COURSE, TYPE S9.5B, AT AN AVERAGE RATE OF 110 LBS. PER SQ. YD. PER 1" DEPTH. TO BE PLACED IN LAYERS NOT TO EXCEED 3" IN DEPTH.
E1	PROP. APPROX. 11" ASPHALT CONCRETE BASE COURSE TYPE B25.0C, AT AN AVERAGE RATE OF 627 LBS. PER SQ. YD. IN EACH OF TWO LAYERS
E2	PROP. VAR. DEPTH ASPHALT CONCRETE BASE COURSE, TYPE B25.0C, AT AN AVERAGE RATE OF 114 LBS. PER SQ. YD. PER 1" DEPTH. TO BE PLACED IN LAYERS NOT LESS THAN 3" IN DEPTH OR GREATER THAN 5 1/2" IN DEPTH.
T	EARTH MATERIAL
U	EXISTING PAVEMENT
V	MILLING BITUMINOUS PAVEMENT. 3" DEPTH.
W	VARIABLE DEPTH ASPHALT PAVEMENT

NOTE: PAVEMENT EDGE SLOPES ARE 1:1 UNLESS SHOWN OTHERWISE.

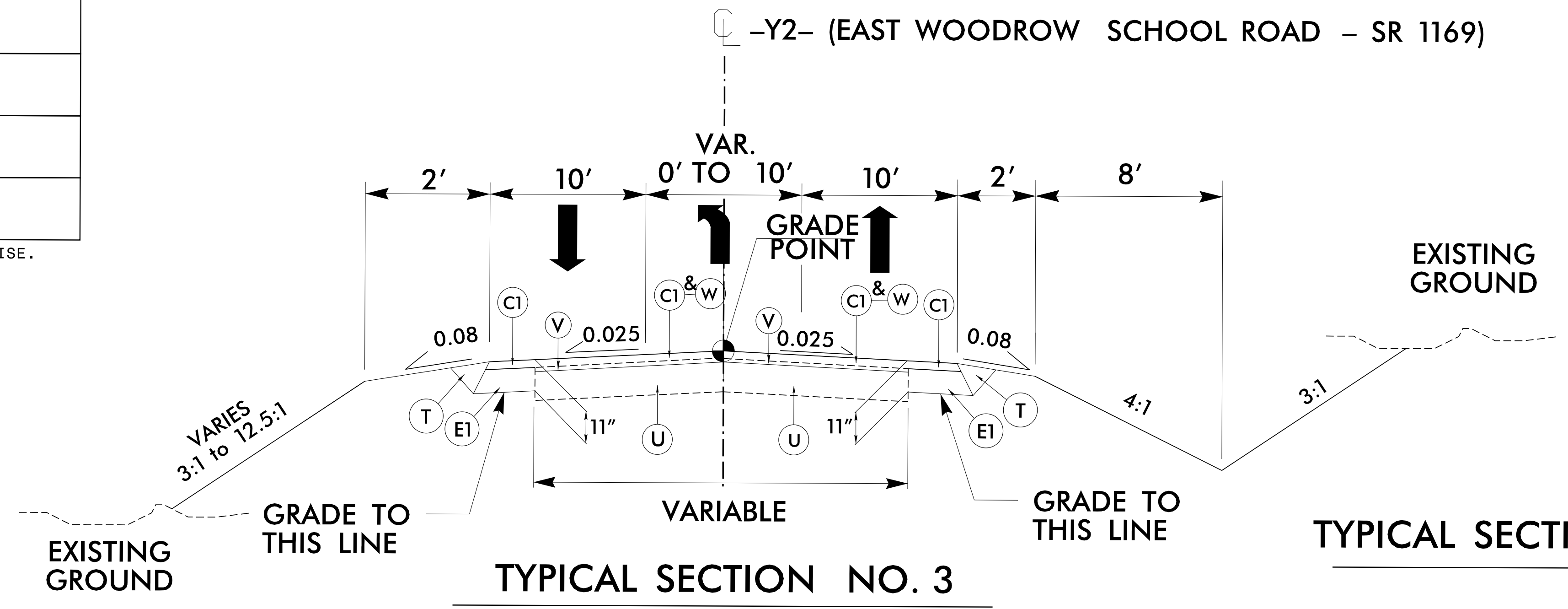

**TYPICAL SECTION NO. 3**

**STA. 11+30 -Y2- TO STA. 12+00 -Y2-**

- NOTE:
1. TRENCH, GRADE AND PLACE E1 TO EXISTING PAVEMENT ELEVATION
  2. MILL 3" ACROSS ENTIRE PROPOSED WIDTH
  3. PLACE FINAL PAVEMENT COURSES (WEDGING AND C1)

5/15/2023 11:44:04 AM  
I:\Projects\W-5701H-rdy-tyj\p.dgn

### SUMMARY OF EARTHWORK IN CUBIC YARDS

STATION	STATION	UNCL. EXCAV.	EMBANK. +%	BORROW	WASTE
-Y1- 11+30	-Y1- 13+56	67	39	0	28
-Y2- 10+11	-Y2- 12+00	553	15	0	538
	SUBTOTAL	620	53	0	566
TOTAL		620	53	0	566
PROJECT TOTALS:					
EST 5% TO REPLACE TOPSOIL					
GRAND TOTALS:					
		620	53	0	566
SAY:		650			

Note: Approximate quantities only. Unclassified Excavation, Fine Grading, Clearing and Grubbing, and Removal of Existing Pavement will be paid for at the contract lump sum price for "Grading."

UNDERCUT EXCAVATION = 300 CY  
 GEOTEXTILE FOR SOIL STABILIZATION = 300 SY  
 SELECT GRANULAR MATERIAL = 300 CY

### PAVEMENT REMOVAL SUMMARY

IN SQUARE YARDS					
LINE	LOCATION	ASPHALT REMOVAL	ASPHALT BREAK-UP	CONCRETE REMOVAL	CONCRETE REMOVAL
-Y1-	11+30 TO 13+56 Rt.	1117			
-Y2-	10+11 TO 12+00 L&Rt	1154			
	TOTAL	2271			
	SAY	2275			



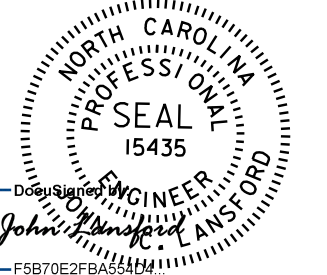
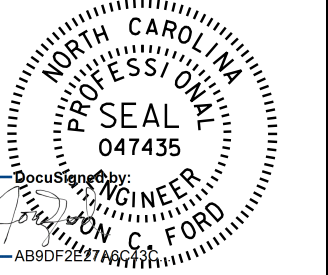

5/14/23

PROJECT REFERENCE NO. <b>W-570IH</b>		SHEET NO. <b>4</b>	
RW SHEET NO.		HYDRAULICS	
ROADWAY DESIGN ENGINEER		ENGINEER	
			
5/3/2023		5/3/2023	
<b>DOCUMENT NOT CONSIDERED FINAL UNLESS ALL SIGNATURES COMPLETED</b>			

<b>CUR DATA -L-</b> Plc 19+61.06 $\Delta c = 03^{\circ}23'00.0''$ (LT) D = 00°30'00.0" Lc = 676.67 Tc = 338.43 R = 11,459.16 SE = Exist.	<b>CUR DATA -Y1-</b> Plc 12+92.97 $\Delta c = 67^{\circ}11'54.7''$ (LT) D = 54°34'02.7" Lc = 123.15 Tc = 69.76 R = 105	<b>CUR DATA -Y2-</b> Plc 10+57.39 $\Delta c = 34^{\circ}07'48.1''$ (RT) D = 45°50'11.8" Lc = 74.46 Tc = 38.37 R = 125	<b>CUR DATA -Y2-</b> Plc 12+05.72 $\Delta c = 06^{\circ}26'28.6''$ (LT) D = 04°15'30.5" Lc = 151.26 Tc = 75.71 R = 1,345.46	<b>CUR DATA -Y2-</b> Plc 13+70.18 $\Delta c = 10^{\circ}59'21.7''$ (LT) D = 06°11'56.8" Lc = 177.27 Tc = 88.91 R = 924.26
---	--	---	---	---

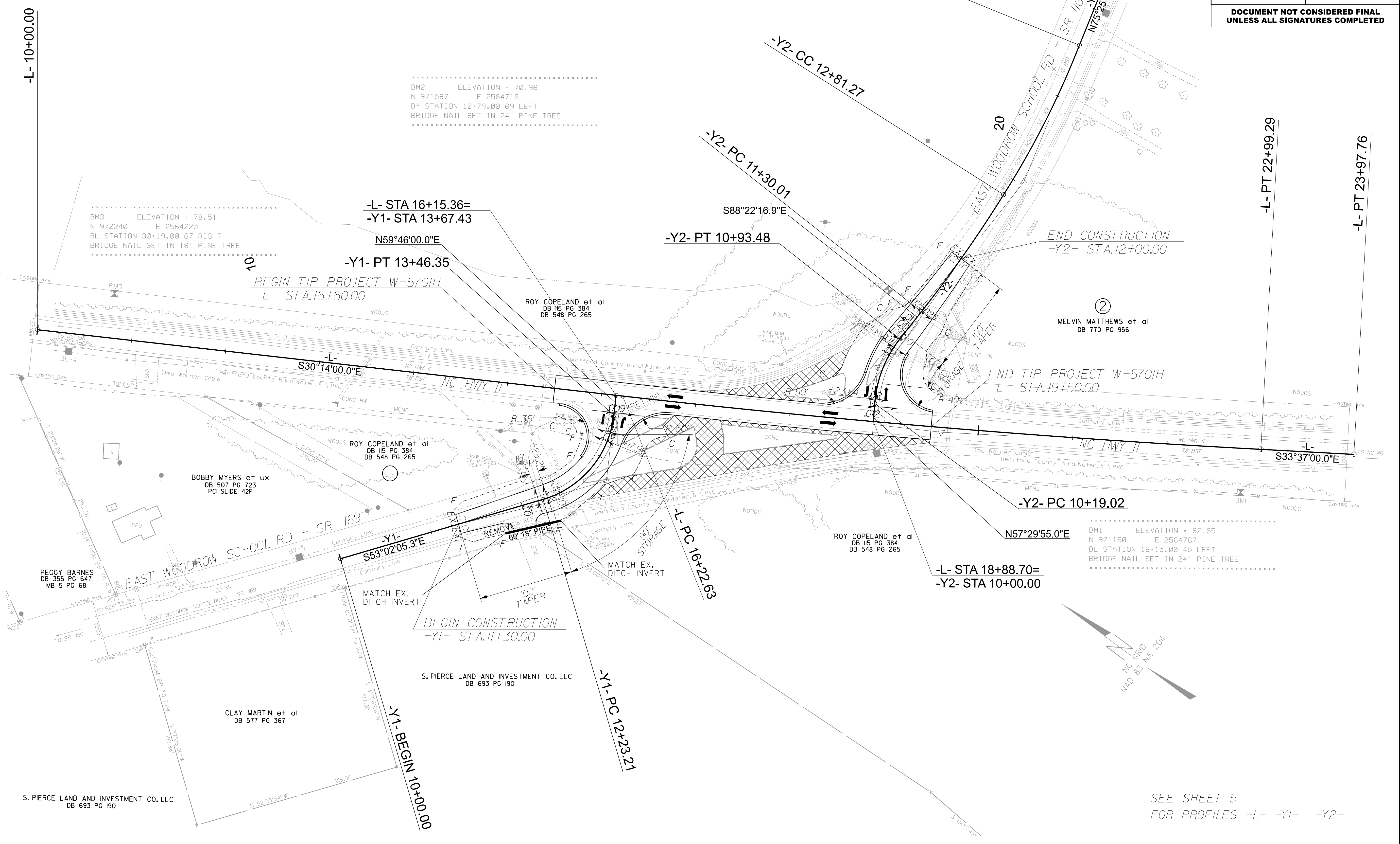

.....  
 BM2 ELEVATION = 70.96  
 N 971587 E 2564716  
 BY STATION 12+79.00 69 LEFT  
 BRIDGE NAIL SET IN 24" PINE TREE  
 .....

.....  
 BM3 ELEVATION = 78.51  
 N 972240 E 2564225  
 BL STATION 30+19.00 67 RIGHT  
 BRIDGE NAIL SET IN 18" PINE TREE  
 .....

.....  
 BM1 ELEVATION = 62.65  
 N 971160 E 2564767  
 BL STATION 18+15.00 45 LEFT  
 BRIDGE NAIL SET IN 24" PINE TREE  
 .....

SEE SHEET 5  
 FOR PROFILES -L- -Y1- -Y2-

5/2/2023 1:44:48 PM  
 W-570IH\_rdy\_psh.dgn  
 User: jhansen



5/28/99

PROJECT REFERENCE NO. <b>W-570IH</b>	SHEET NO. <b>5</b>
ROADWAY DESIGN ENGINEER	HYDRAULICS ENGINEER

**DOCUMENT NOT CONSIDERED FINAL UNLESS ALL SIGNATURES COMPLETED**

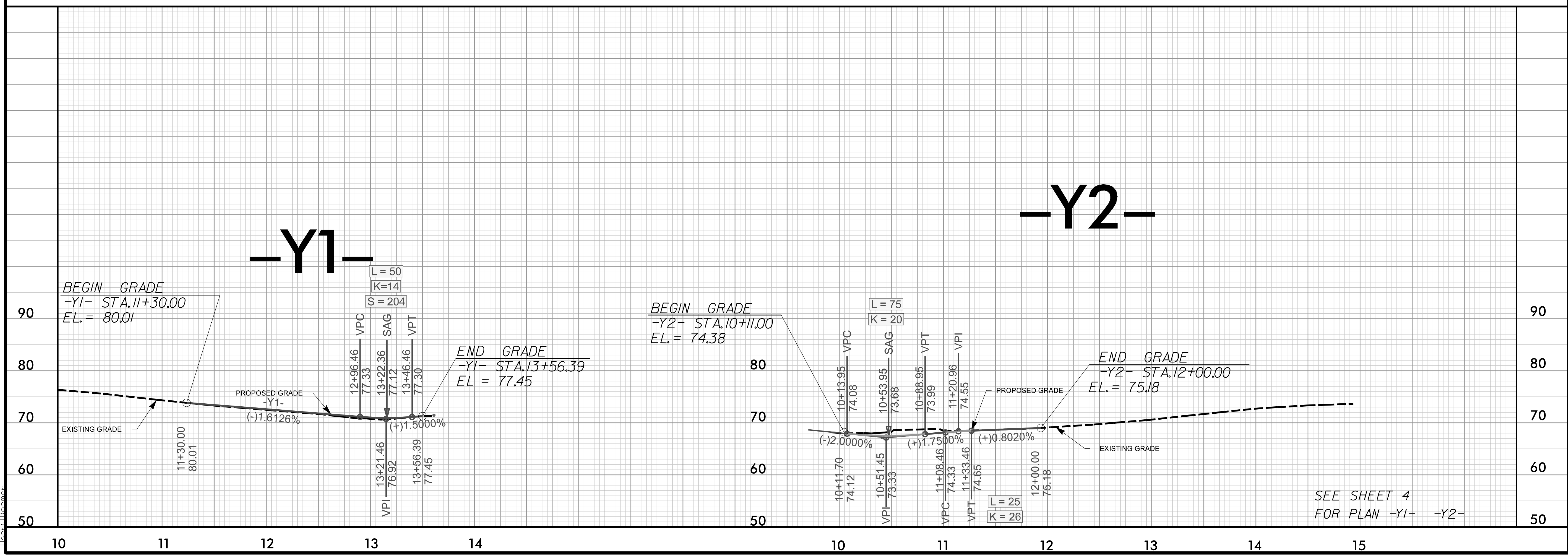
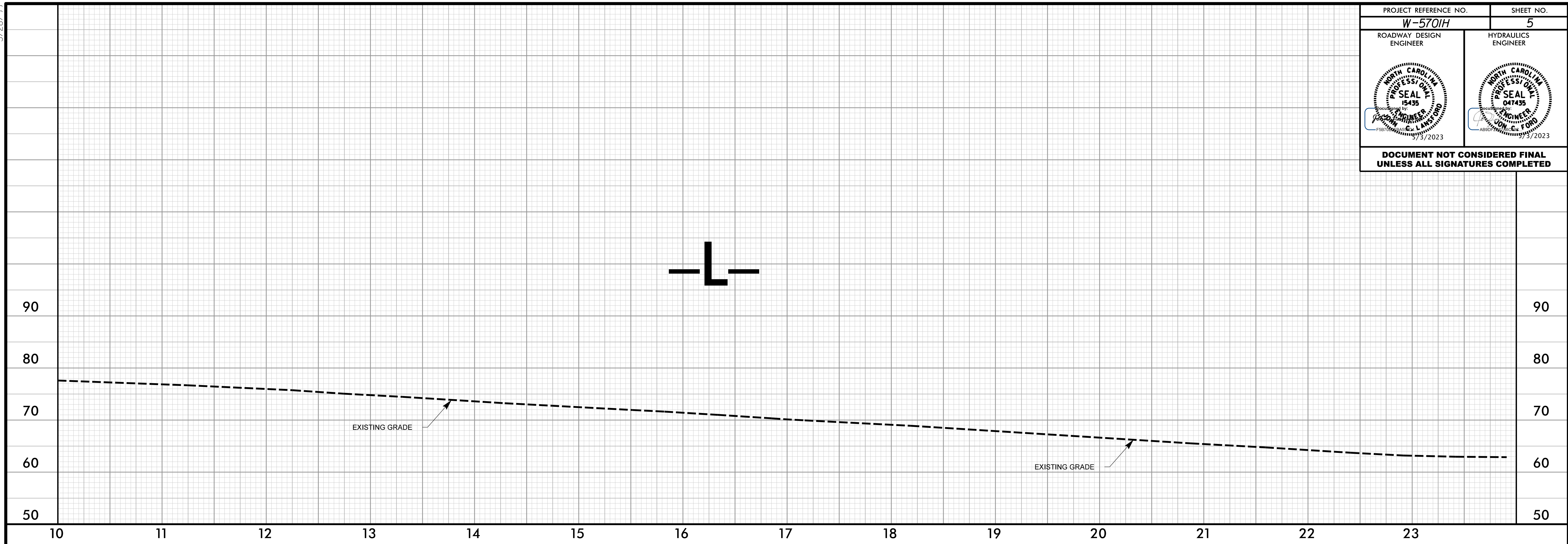

4/28/2023 11:35:31 AM  
\\s01\cadd\w\570\11\11-dy-pl.dgn  
m.laeger







STATE OF NORTH CAROLINA  
DIVISION OF HIGHWAYS

**TRANSPORTATION MANAGEMENT PLAN**

**HERTFORD COUNTY**

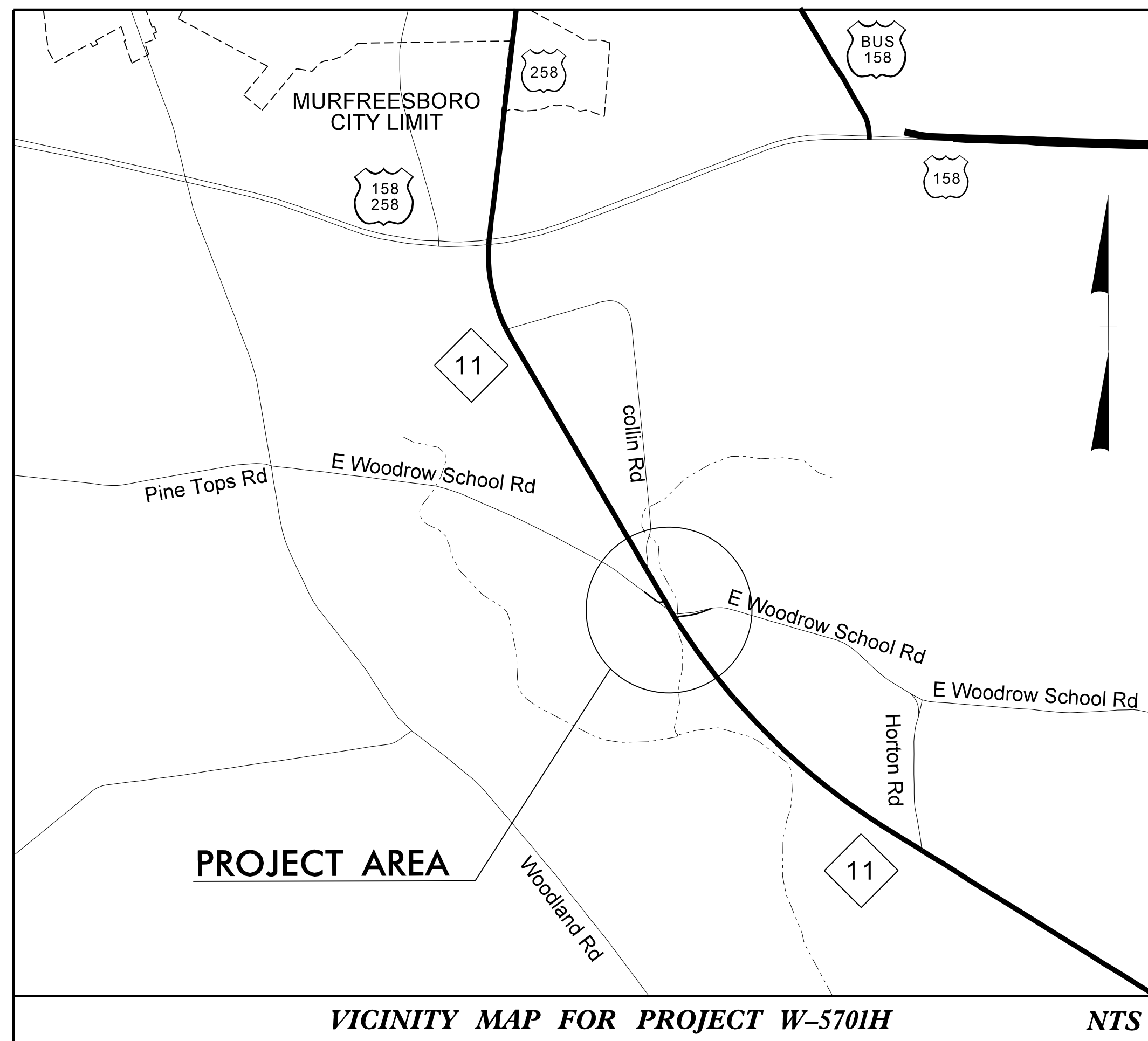
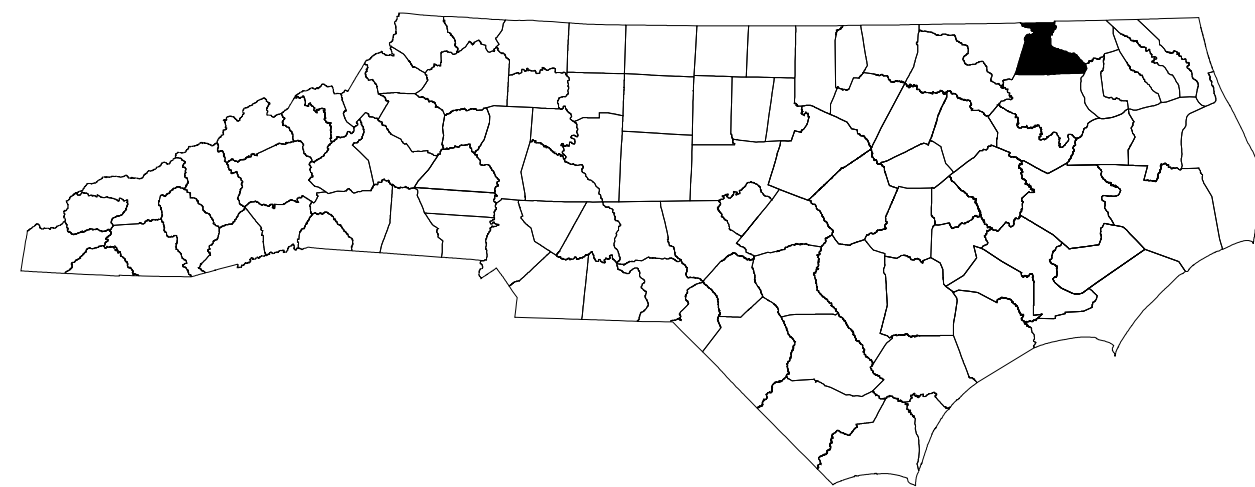

**INDEX OF SHEETS**

SHEET NO.	TITLE
TMP-1	TITLE SHEET, VICINITY MAP, AND INDEX OF SHEETS
TMP-1A	ROADWAY STANDARD DRAWINGS, GENERAL NOTES, LEGEND, & MANAGEMENT STRATEGIES
TMP-2	SPECIAL SIGN DESIGN
TMP-3	TEMPORARY TRAFFIC CONTROL PHASE 1 DETAIL
TMP-4	TEMPORARY TRAFFIC CONTROL PHASE 2 DETAIL

SHEET NO.  
TMP-1

**W-5701H**

**TIP PROJECT:**

**DOCUMENT NOT CONSIDERED FINAL  
UNLESS ALL SIGNATURES COMPLETED**



**PLANS PREPARED BY:**

KYLE COMPTON, PE  
PROJECT ENGINEER

JARED PHILPOT  
PROJECT DESIGN ENGINEER

**NCDOT CONTACTS:**

PROJECT ENGINEER

PROJECT DESIGN ENGINEER

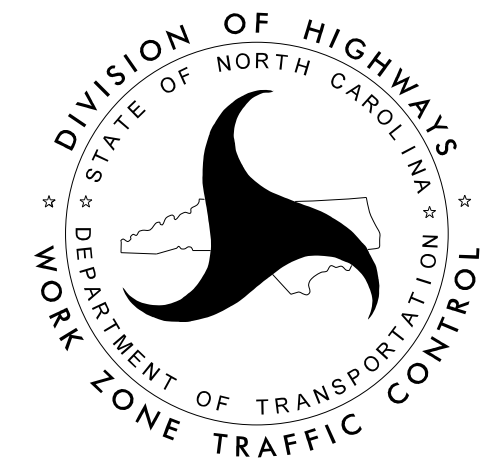

**V&M**  
Vaughn & Melton  
Consulting Engineers

Asheville, North Carolina  
828-253-4796

Raleigh, NC 919-977-9455      Charlotte, NC 704-357-0488

Boone, NC 828-355-9933      Tri-Cities, TN 423-467-8400

Knoxville, TN 865-546-5800      Spartanburg, SC 864-574-4775

Charleston, SC 843-974-5650      Middlesboro, KY 606-328-6600

Atlanta, GA 770-627-3590

Copyright © 2006 Vaughn & Melton, Inc. All Rights Reserved

APPROVED: *Kyle H. Compton*  
DATE: 5/2/2023

SEAL  
KYLE H. COMPTON  
ENGINEER  
041998

4/26/2023 10:28:36 AM V:\NC\Transportation\03737-14 NCI\Hertford\Workzone Traffic Control\WZTC\W-5701H\_TMP\_TSH.dgn User:dfreede

# ROADWAY STANDARD DRAWINGS

THE FOLLOWING ROADWAY STANDARDS AS SHOWN IN "ROADWAY STANDARD DRAWINGS" - PROJECT SERVICES UNIT - N.C. DEPARTMENT OF TRANSPORTATION - RALEIGH, N.C., DATED JANUARY 2018 ARE APPLICABLE TO THIS PROJECT AND BY REFERENCE HEREBY ARE CONSIDERED A PART OF THESE PLANS:

STD. NO.	TITLE
1101.01	WORK ZONE ADVANCE WARNING SIGNS
1101.03	TEMPORARY ROAD CLOSURES
1101.04	TEMPORARY SHOULDER CLOSURES
1101.11	TRAFFIC CONTROL DESIGN TABLES
1110.01	STATIONARY WORK ZONE SIGNS
1145.01	BARRICADES

## MANAGEMENT STRATEGIES

- CLOSE SR 1169 (E WOODROW SCHOOL RD) TO TRAFFIC AND DETOUR OFF-SITE.
- ACCESS TO ALL RESIDENTS WITHIN THE PROJECT LIMITS MUST BE MAINTAINED AT ALL TIMES.

## LEGEND

### GENERAL

 NORTH ARROW

### TRAFFIC CONTROL DEVICES

 BARRICADE (TYPE III)

### TEMPORARY SIGNING

 STATIONARY SIGN

# GENERAL NOTES

CHANGES MAY BE REQUIRED WHEN PHYSICAL DIMENSIONS IN THE DETAIL DRAWINGS, STANDARD DETAILS AND ROADWAY DETAILS ARE NOT ATTAINABLE TO MEET FIELD CONDITIONS, OR RESULT IN DUPLICATE, OR UNDESIRE OVERLAPPING OF DEVICES. MODIFICATION MAY INCLUDE: MOVING, SUPPLEMENTING, COVERING OR REMOVAL OF DEVICES, AS DIRECTED BY THE ENGINEER.

THE FOLLOWING GENERAL NOTES APPLY AT ALL TIMES FOR THE DURATION OF THE CONSTRUCTION PROJECT, EXCEPT WHEN OTHERWISE NOTED IN THE PLAN, OR DIRECTED BY THE ENGINEER.

### LANE AND SHOULDER CLOSURE REQUIREMENTS

- WHEN PERSONNEL AND/OR EQUIPMENT ARE WORKING WITHIN 15 FT OF AN OPEN TRAVEL LANE, CLOSE THE NEAREST OPEN SHOULDER USING ROADWAY STANDARD DRAWING NO. 1101.04 UNLESS THE WORK AREA IS PROTECTED BY BARRIER OR GUARDRAIL OR A LANE CLOSURE IS INSTALLED.
- WHEN PERSONNEL AND/OR EQUIPMENT ARE WORKING ON THE SHOULDER ADJACENT TO AN UNDIVIDED FACILITY AND WITHIN 5 FT OF AN OPEN TRAVEL LANE, CLOSE THE NEAREST OPEN TRAVEL LANE USING ROADWAY STANDARD DRAWING NO. 1101.02 UNLESS THE WORK AREA IS PROTECTED BY BARRIER OR GUARDRAIL.

WHEN PERSONNEL AND/OR EQUIPMENT ARE WORKING ON THE SHOULDER ADJACENT TO A DIVIDED FACILITY AND WITHIN 10 FT OF AN OPEN TRAVEL LANE, CLOSE THE NEAREST OPEN TRAVEL LANE USING ROADWAY STANDARD DRAWING NO. 1101.02 UNLESS THE WORK AREA IS PROTECTED BY BARRIER OR GUARDRAIL.

- DO NOT WORK SIMULTANEOUSLY WITHIN 15 FT ON BOTH SIDES OF AN OPEN TRAVELWAY, RAMP, OR LOOP WITHIN THE SAME LOCATION UNLESS PROTECTED WITH GUARDRAIL OR BARRIER.

### PAVEMENT EDGE DROP OFF REQUIREMENTS

#### TRAFFIC PATTERN ALTERATIONS

- NOTIFY THE ENGINEER THIRTY (30) CALENDAR DAYS PRIOR TO ANY TRAFFIC PATTERN ALTERATION.

### SIGNING

- INSTALL ADVANCE WORK ZONE WARNING SIGNS WHEN WORK IS WITHIN 40 FT FROM THE EDGE OF TRAVEL LANE AND NO MORE THAN THREE (3) DAYS PRIOR TO THE BEGINNING OF CONSTRUCTION.
- ENSURE ALL NECESSARY SIGNING IS IN PLACE PRIOR TO ALTERING ANY TRAFFIC PATTERN.

### TRAFFIC CONTROL DEVICES

- PLACE TYPE III BARRICADES, WITH "ROAD CLOSED" SIGN R11-2 ATTACHED, OR SUFFICIENT LENGTH TO CLOSE ENTIRE ROADWAY.

### PAVEMENT MARKINGS AND MARKERS

- TIE PROPOSED PAVEMENT MARKING LINES TO EXISTING PAVEMENT MARKING LINES.
- REMOVE/REPLACE ANY CONFLICTING/DAMAGED PAVEMENT MARKINGS AND MARKERS BY THE END OF EACH DAY'S OPERATION.

# LOCAL NOTES

- NOTIFY HERTFORD COUNTY EMERGENCY SERVICES AND PUBLIC SCHOOLS AT LEAST ONE MONTH PRIOR TO ROAD CLOSURE.

**DOCUMENT NOT CONSIDERED FINAL  
UNLESS ALL SIGNATURES COMPLETED**

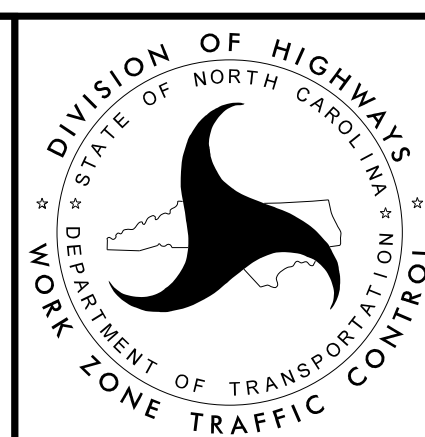
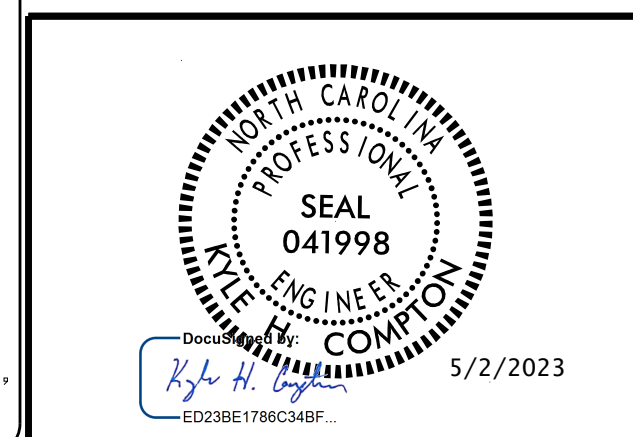
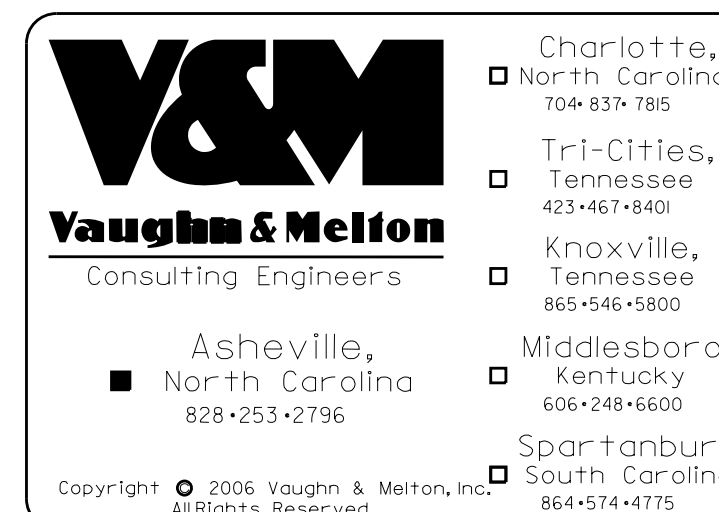

ROADWAY STANDARD DRAWINGS,  
GENERAL NOTES  
MANAGEMENT STRATEGIES

SIGN NUMBER: SP-1      BACKG COLOR: Orange  
 TYPE: D                              COPY COLOR: Black      DESIGN BY: DF      CHECKED BY: JR      DATE: 4/21/2023  
 QUANTITY: 20      PROJECT ID: W-5701H      DIV: 1

SYMBOL	X	Y	WID	HT

SIGN WIDTH: 3'-0"  
 HEIGHT: 2'-0"  
 TOTAL AREA: 6.0 Sq.-Ft.

BORDER TYPE: FLUSH  
 RECESS: 0.47"  
 WIDTH: 0.63"  
 RADII: 1.5"

NO. Z BARS: N/A  
 LENGTH: N/A

MAT'L: 0.125" (3.2 mm) ALUMINUM

USE NOTES: 1,2  
 1. Legend and border shall be direct applied black non-reflective sheeting.  
 2. Background shall be Grade A, B, or C reflective sheeting.

BORDER  
 R=1.5"  
 TH=0.63"  
 IN=0.47"

Spacing Factor is 1 unless specified otherwise

LETTER POSITIONS

Letter spacings are to start of next letter

Letter spacings are to start of next letter												Series/Size
												Text Length
E		W	O	O	D	R	O	W				D 2000
4.2	6.2	10.2	13.8	16.8	20	23	25.9	28.7				27.6
S	C	H	O	O	L		R	D				D 2000
5.4	8.3	11.3	14.4	17.4	20.6	22.6	26.6	29.6				26.5

FILENAME: TMP-3      NORTH CAROLINA D.O.T. SIGN DETAIL

4/26/2023 10:33:00 AM  
V:\NcTransportation\031737-14 NCI\Hertford\Workzone Traffic Control\WZTC\W-5701H\_TMP\_Guide\_sign.dgn  
User:dfreddie

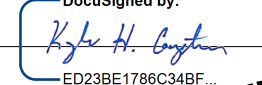
APPROVED:   
 DATE: 5/2/2023

SEAL

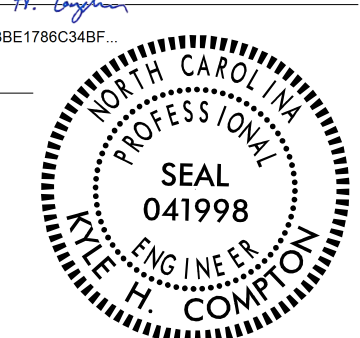
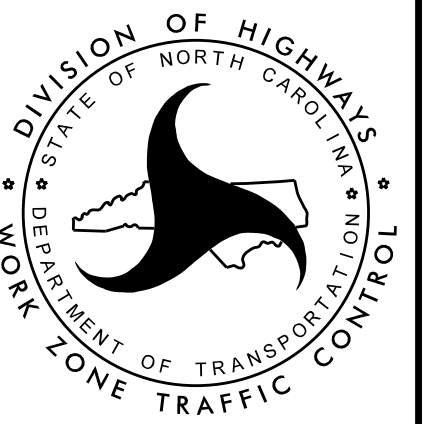
SPECIAL SIGN DESIGN



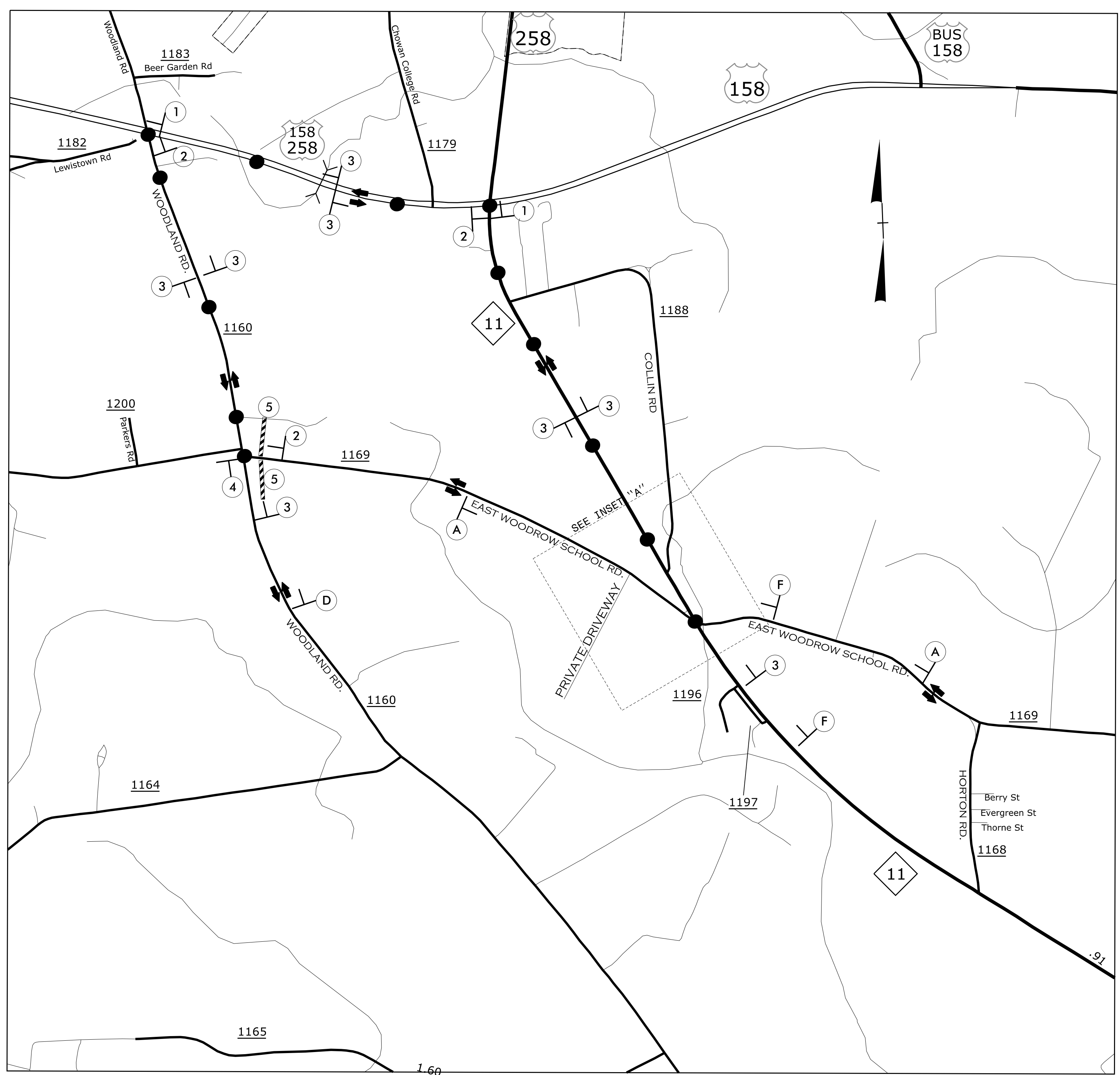

● ● ● DETOUR ROUTE (4.62 mi. +/-)

- PHASE 1:
- STEP 1: - INSTALL OFF-SITE DETOUR ROUTE ASSEMBLIES FOR THE CLOSING OF SR 1169 (EAST WOODROW SCHOOL RD, -Y1-). USING ROADWAY STANDARD DRAWING NO. 1101.03, SHEET 1 AND 2 OF 9, CLOSE SR 1169 (EAST WOODROW SCHOOL RD, -Y1-) TO THRU TRAFFIC.
  - STEP 2: - CONSTRUCT THE PROPOSED ROADWAY UP TO AND INCLUDING THE FINAL LAYER OF SURFACE COURSE ON SR 1169 (EAST WOODROW SCHOOL RD, -Y1-). (SEE ROADWAY PLANS).
  - REMOVE ALL TRAFFIC CONTROL DEVICES, SIGNING AND DETOUR ROUTE SIGNING.
  - OPEN SR 1169 (EAST WOODROW SCHOOL RD -Y1-) TO ITS FINAL TRAFFIC PATTERN.

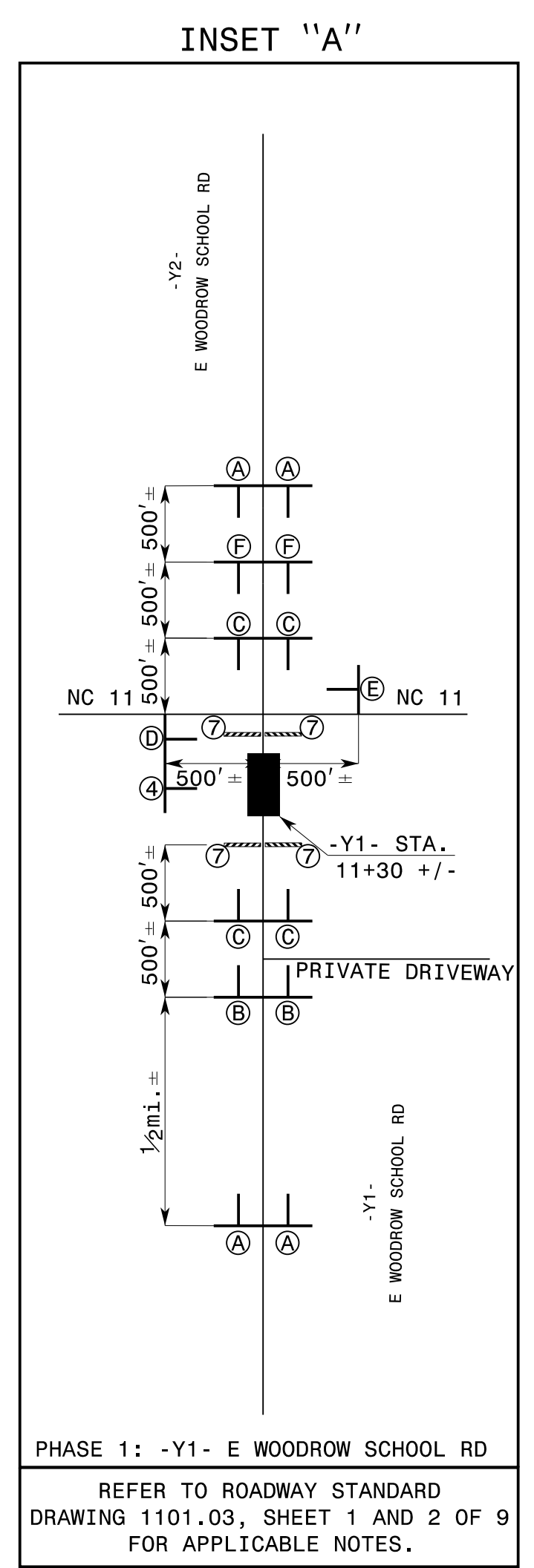

- SIGN 1:** DETOUR (M4-8 24" X 12"), E WOODROW SCHOOL RD (SP-1 36" X 24"), ROAD CLOSED AHEAD (W20-3 48" X 48"), M6-1 L (21" X 15")
- SIGN 2:** DETOUR (M4-8 24" X 12"), E WOODROW SCHOOL RD (SP-1 36" X 24"), ROAD CLOSED 1000 FT (W20-3 48" X 48"), M6-1 (21" X 15")
- SIGN 3:** DETOUR (M4-8 24" X 12"), E WOODROW SCHOOL RD (SP-1 36" X 24"), ROAD CLOSED 500 FT (W20-3 48" X 48"), M6-3 (21" X 15")
- SIGN 4:** E WOODROW SCHOOL RD (SP-1 36" X 24"), END DETOUR (M4-8 A 24" X 18"), ROAD CLOSED AHEAD (W20-3 48" X 48"), NEXT RIGHT (SP-4R 42" X 12")
- SIGN 5:** ROAD CLOSED TO THRU TRAFFIC (R11-4 60" X 30"), TYPE III BARRICADE (M4-10L 48" X 18"), ROAD CLOSED AHEAD (W20-3 48" X 48"), NEXT LEFT (SP-4L 42" X 12")
- SIGN 6:** ROAD CLOSED TO THRU TRAFFIC (R11-4 60" X 30"), TYPE III BARRICADE (M4-10R 48" X 18"), DETOUR AHEAD (W20-2 48" X 48")
- SIGN 7:** ROAD CLOSED (R11-2 48" X 30"), TYPE III BARRICADE(S)

4/26/2023 10:39:48 AM V:\NCTrans\Information\031737-14 NCI\Herf\ford\Workzone Traffic Control\WZTC\W-5701H-TMP-TMP3(Y1).dgn User:dfredd

APPROVED: *[Signature]*  
DATE: 5/2/2023

SEAL

PROFESSIONAL SEAL  
041998  
KYLE H. COMPTON  
ENGINEER

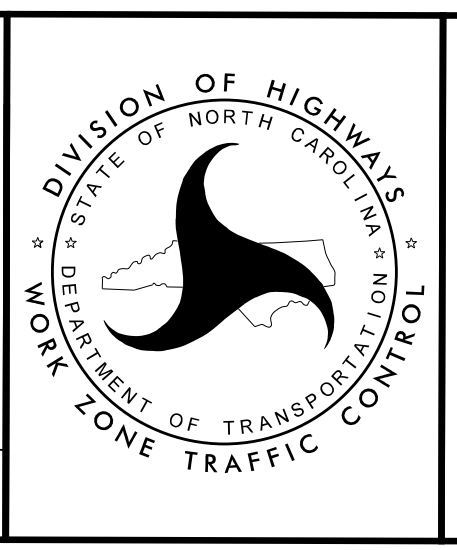

TEMPORARY TRAFFIC CONTROL PHASE 1 DETAIL

DOCUMENT NOT CONSIDERED FINAL UNLESS ALL SIGNATURES COMPLETED

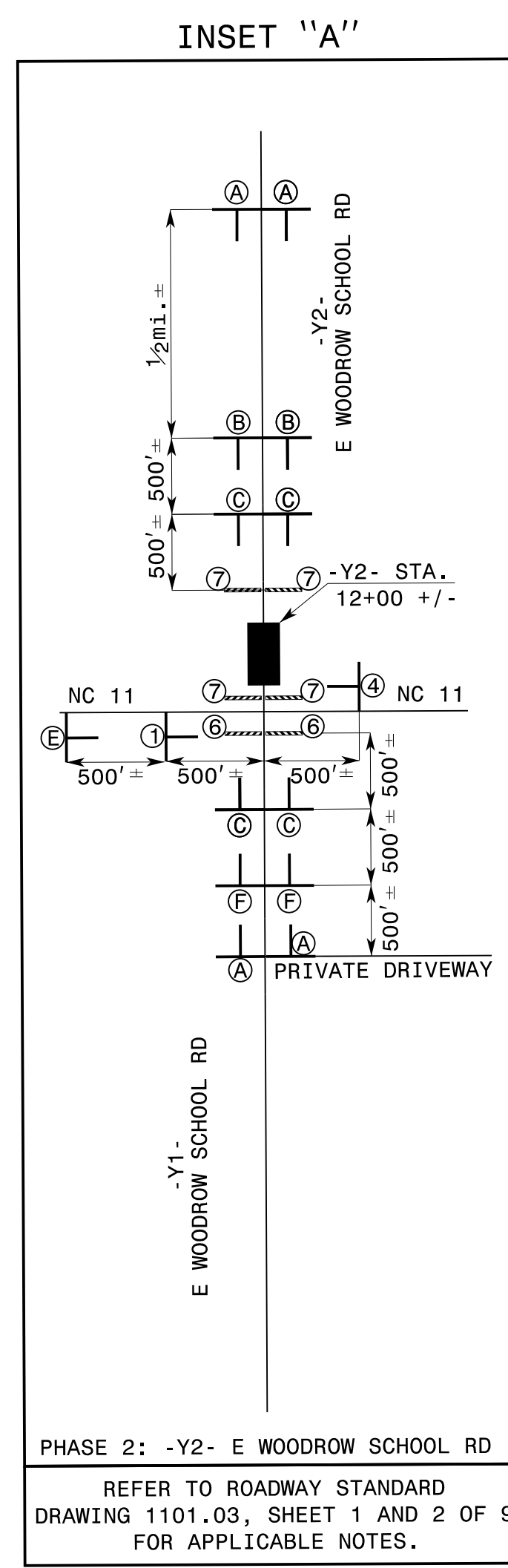
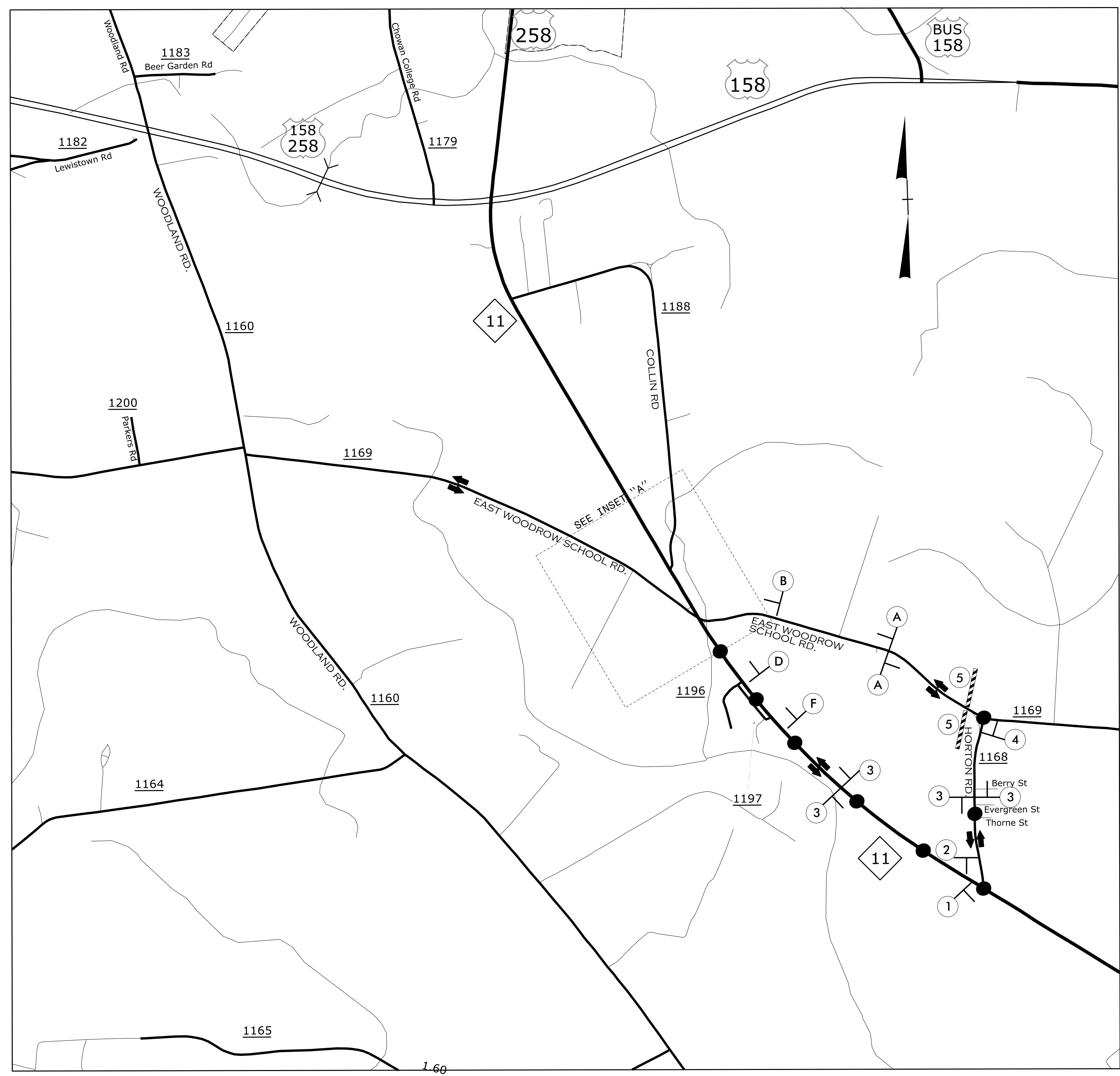

- PHASE 2: ●—●—●—● DETOUR ROUTE (2.50 mi. +/-)
- STEP 1: - INSTALL OFF-SITE DETOUR ROUTE ASSEMBLIES FOR THE CLOSING OF SR 1169 (EAST WOODROW SCHOOL RD, -Y2-).  
 - USING ROADWAY STANDARD DRAWING NO. 1101.03, SHEET 1 AND 2 OF 9, CLOSE SR 1169 (EAST WOODROW SCHOOL RD, -Y2-) TO THRU TRAFFIC.
- STEP 2: - CONSTRUCT THE PROPOSED ROADWAY UP TO AND INCLUDING THE FINAL LAYER OF SURFACE COURSE ON SR 1169 (EAST WOODROW SCHOOL RD -Y2-). (SEE ROADWAY PLANS).  
 - REMOVE ALL TRAFFIC CONTROL DEVICES SIGNING AND DETOUR ROUTE SIGNING.  
 - OPEN 1169 (EAST WOODROW SCHOOL RD -Y2-) TO ITS FINAL TRAFFIC PATTERN.

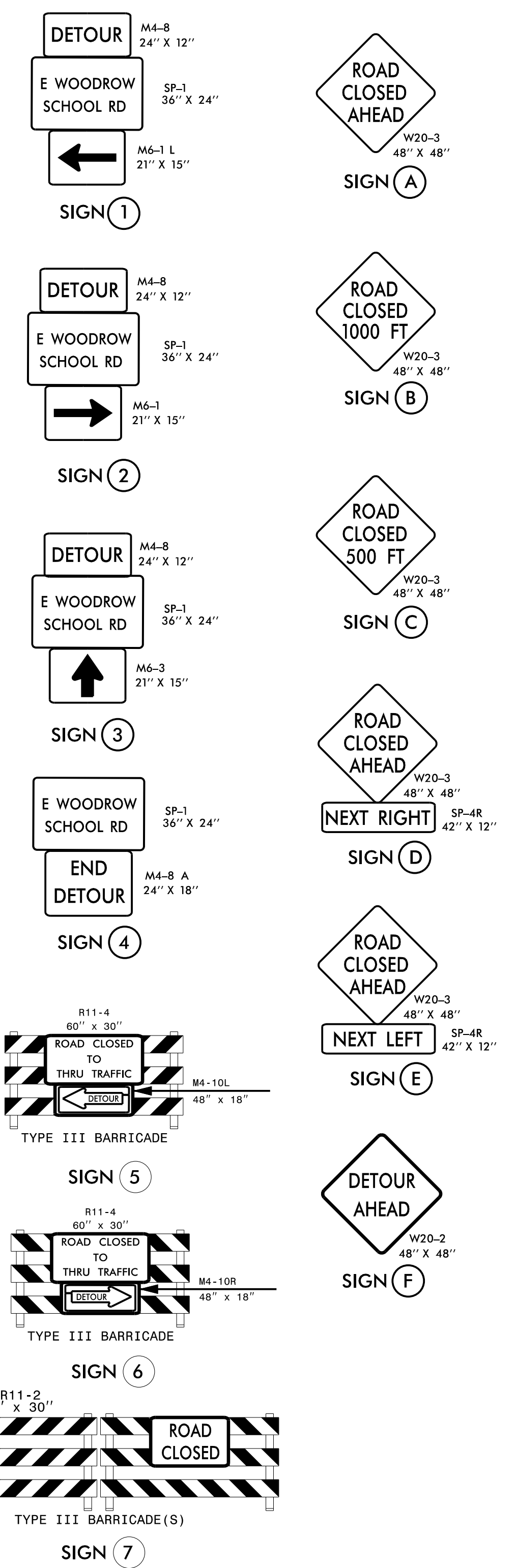

5/2/2023 11:45:16 AM  
 C:\Users\jcorbett\OneDrive\Workzone Traffic Control\WZTC\W-5701H\_TMP-TMP-4(V2).dgn  
 User: jcorbett

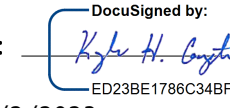
APPROVED:   
 DATE: 5/2/2023

SEAL

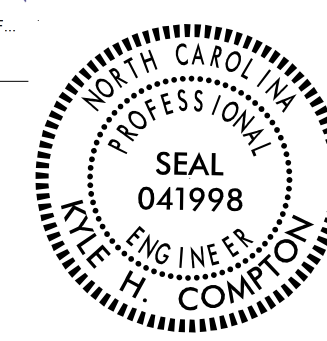

DOCUMENT NOT CONSIDERED FINAL UNLESS ALL SIGNATURES COMPLETED

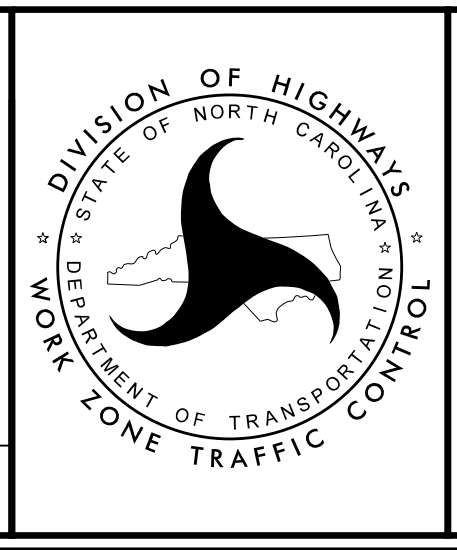

TEMPORARY TRAFFIC CONTROL PHASE 2 DETAIL

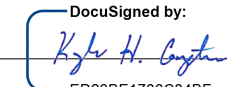
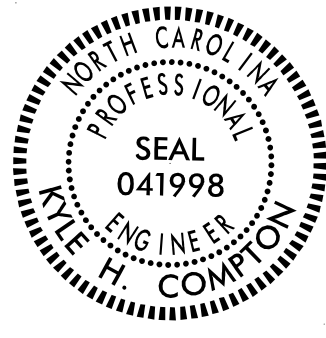

STATE OF NORTH CAROLINA  
DEPARTMENT OF TRANSPORTATION

TIP NO.	SHEET NO.
W-5701H	PMP - 1
APPROVED:  DATE: 1/10/2023	
SEAL 	
DOCUMENT NOT CONSIDERED FINAL UNLESS ALL SIGNATURES COMPLETED	

PAVEMENT MARKING PLAN

HERTFORD COUNTY

LOCATION: NC-11 INTERSECTION AT SR 1169 (E WOODROW SCHOOL RD)

INDEX

SHEET NO.	DESCRIPTION
PMP-1	PAVEMENT MARKING PLAN COVER SHEET & PAVMENT MARKING SCHEDULE
PMP-2	PAVEMENT MARKING DETAILS

PAVEMENT MARKING SCHEDULE

SYMBOL	DESCRIPTION	MATERIAL
T1	WHITE EDGELINE (4",90 MIL)	THERMOPLASTIC
T2	WHITE SOLID LANE LINE (4",90 MIL)	THERMOPLASTIC
T5	2FT. - 6 FT. /SP WHITE MINISKIP(4",90 MIL)	THERMOPLASTIC
T13	YELLOW DOUBLE CENTER (4",90 MIL)	THERMOPLASTIC
T61	WHITE STOPBAR (24",90 MIL)	THERMOPLASTIC
T70	LEFT TURN ARROW (90 MIL)	THERMOPLASTIC
T71	RIGHT TURN ARROW (90 MIL)	THERMOPLASTIC

ROADWAY STANDARD DRAWING

THE FOLLOWING ROADWAY STANDARDS AS APPEAR IN "ROADWAY STANDARD DRAWINGS" - PROJECT SERVICES UNIT - N.C. DEPARTMENT OF TRANSPORTATION - RALEIGH, N.C., DATED JANUARY 2018 ARE APPLICABLE TO THIS PROJECT AND BY REFERENCE HEREBY ARE CONSIDERED A PART OF THESE PLANS:

STD. NO.	TITLE
1205.01	PAVEMENT MARKINGS - LINE TYPES AND OFFSETS
1205.02	PAVEMENT MARKINGS - TWO-LANE AND MULTILANE ROADWAYS
1205.04	PAVEMENT MARKINGS - INTERSECTIONS
1205.05	PAVEMENT MARKINGS - TURN LANES
1205.08	PAVEMENT MARKINGS - SYMBOLS AND WORD MESSAGES
1205.09	PAVEMENT MARKINGS - PAINTED ISLANDS
1250.01	RAISED PAVEMENT MARKERS - INSTALLATION SPACING
1253.01	RAISED PAVEMENT MARKERS - SNOWPLOWABLE

GENERAL NOTES

THE FOLLOWING GENERAL NOTES APPLY AT ALL TIMES FOR THE DURATION OF THE CONSTRUCTION PROJECT, EXCEPT WHEN OTHERWISE NOTED IN THE PLAN, OR DIRECTED BY THE ENGINEER.

A) INSTALL PAVEMENT MARKINGS AND PAVEMENT MARKERS ON THE FINAL SURFACE AS FOLLOWS:

ROAD NAME	MARKING	MARKER
ALL ROADS	THERMOPLASTIC	SNOWPLOWABLE/ REFLECTIVE

- B) TIE PROPOSED PAVEMENT MARKING LINES TO EXISTING PAVEMENT MARKING LINES.
- C) REMOVE/REPLACE ANY CONFLICTING/DAMAGED PAVEMENT MARKINGS AND MARKERS.
- D) PASSING ZONES WILL BE DETERMINED IN THE FIELD AND MUST BE APPROVED BY THE ENGINEER.
- E) STOP BAR LOCATION AT NON-SIGNALIZED INTERSECTIONS MAY BE ADJUSTED AS DIRECTED BY THE ENGINEER.
- F) UNLESS OTHERWISE SPECIFIED, HEATED-IN-PLACE THERMOPLASTIC MAY BE USED IN LIEU OF EXTRUDED THERMOPLASTIC FOR STOP BARS, SYMBOLS, CHARACTERS AND DIAGONALS. IF HEATED-IN-PLACE IS USED, IT SHALL BE PAID FOR USING THE EXTRUDED THERMOPLASTIC PAY ITEM.

TIP PROJECT : W-5701H

IV/2/2022 4:5:07 PM V:\NC\Transportation\031737-14 NC\Hertford\Signing and Delmeation\W-5701H.PMP\_TSH.dgn User:amfitzpatrick

PLAN PREPARED BY: Vaughn & Melton Consulting Engineers, INC.

KYLE COMPTON, PE PROJECT ENGINEER

JARED PHILPOT PROJECT DESIGN ENGINEER



- ▣ Raleigh, NC 919-377-9455
- ▣ Charlotte, NC 704-351-0488
- ▣ Boone, NC 828-255-9333
- ▣ Tri-Cities, TN 423-461-8400
- ▣ Tri-Cities, TN 423-461-8400
- ▣ Knoxville, TN 865-546-5800
- ▣ Charleston, SC 843-974-9600
- ▣ Middleboro, KY 606-248-6600
- ▣ Atlanta, GA 770-421-3529
- ▣ Spartanburg, SC 864-574-4775

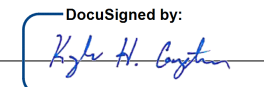
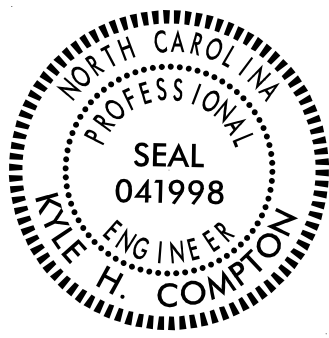

TIP NO.	SHEET NO.
W-5701H	PMP-2
APPROVED: 	
DATE: 1/10/2023	
SEAL	
	
DOCUMENT NOT CONSIDERED FINAL UNLESS ALL SIGNATURES COMPLETED	

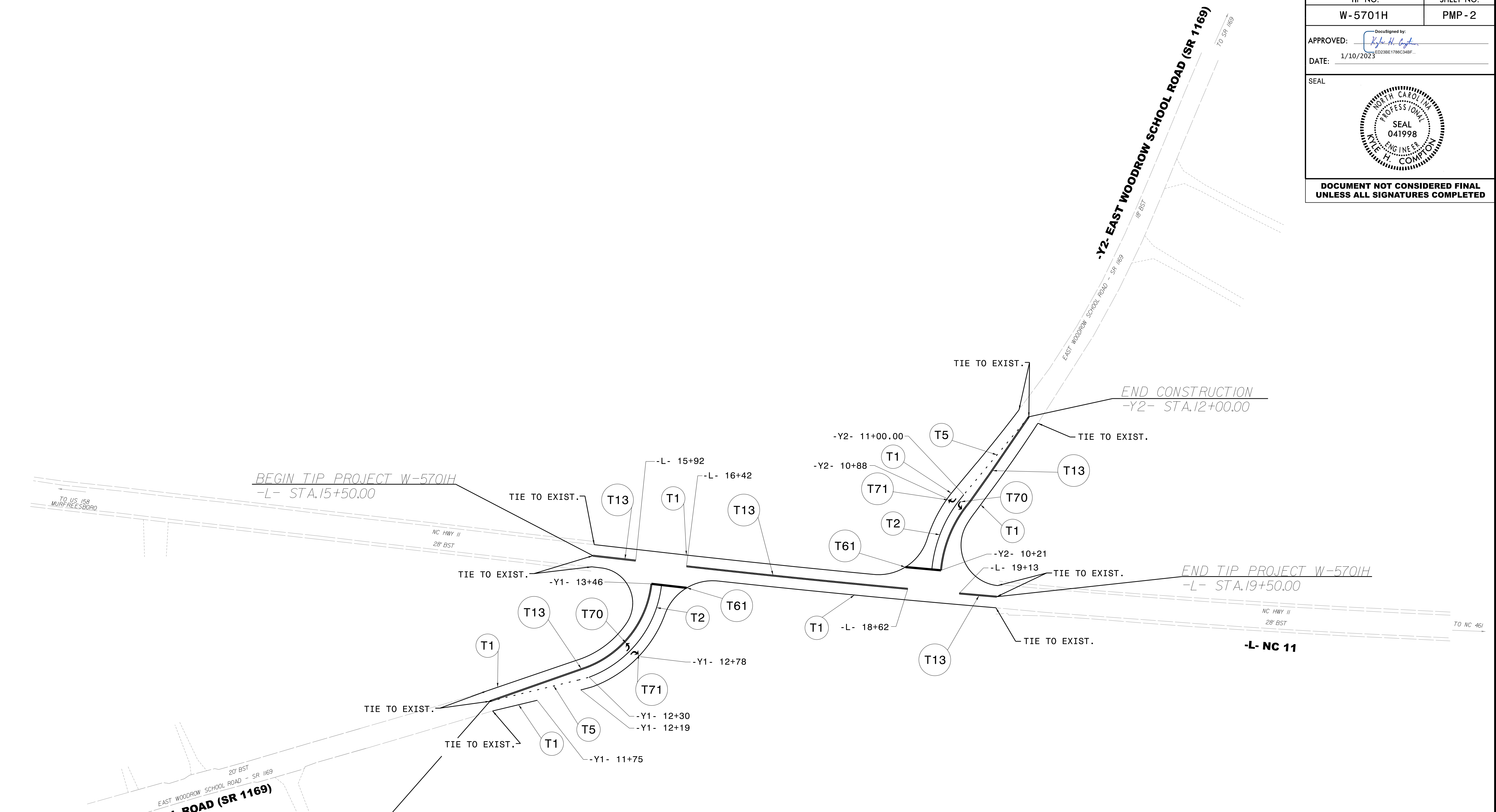

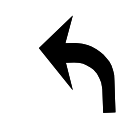
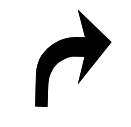
<b>PAVEMENT MARKING SCHEDULE</b>	
SYMBOL	DESCRIPTION
	T70
	T71

**PAVEMENT MARKING DETAIL**

11/2/2022 10:42:29 PM  
 V:\NG\Transportation\031737-14 NCHHertford\Signing and Delineation\W-5701H\_PMP\_2.dgn  
 User:cmfittzpatrick

09.08/2022

**TIP PROJECT: W-5701H**

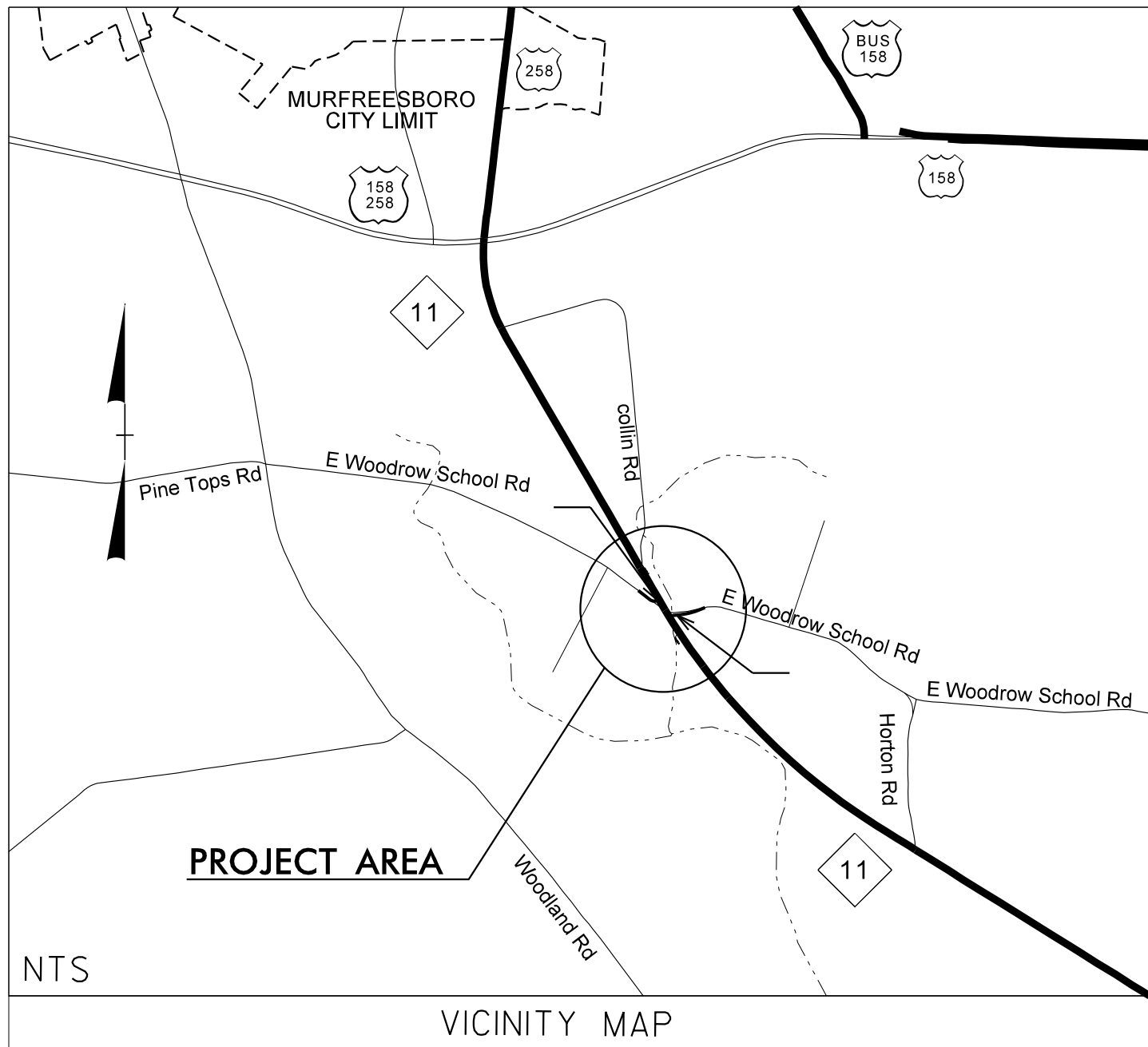

STATE OF NORTH CAROLINA  
DIVISION OF HIGHWAYS

**PLAN FOR PROPOSED  
HIGHWAY EROSION CONTROL**

**HERTFORD COUNTY**

**LOCATION: NC 11 INTERSECTION AT SR 1169 (E WOODROW SCHOOL RD)**  
**TYPE OF WORK: GRADING, DRAINAGE AND PAVING**

STATE	STATE PROJECT REFERENCE NO.	SHEET NO.	TOTAL SHEETS
N.C.	W-5701H	EC-1	
STATE PROJ. NO.	F.A. PROJ. NO.	DESCRIPTION	

**EROSION AND SEDIMENT CONTROL MEASURES**

Std. #	Description	Symbol
1630.03	Temporary Silt Ditch	TD
1630.05	Temporary Diversion	TD
1605.01	Temporary Silt Fence	III III III
1606.01	Special Sediment Control Fence	~ ~ ~
1622.01	Temporary Berms and Slope Drains	T
1630.02	Silt Basin Type B	Silt Basin Symbol
1633.01	Temporary Rock Silt Check Type-A	Rock Silt Check Symbol
	Temporary Rock Silt Check Type-A with Matting and Polyacrylamide (PAM)	Rock Silt Check Symbol
1633.02	Temporary Rock Silt Check Type-B	Rock Silt Check Symbol
	Wattle / Coir Fiber Wattle	Wattle Symbol
	Wattle / Coir Fiber Wattle with Polyacrylamide (PAM)	Wattle Symbol
1634.01	Temporary Rock Sediment Dam Type-A	Rock Sediment Dam Symbol
1634.02	Temporary Rock Sediment Dam Type-B	Rock Sediment Dam Symbol
1635.01	Rock Pipe Inlet Sediment Trap Type-A	Rock Pipe Inlet Sediment Trap Symbol
1635.02	Rock Pipe Inlet Sediment Trap Type-B	Rock Pipe Inlet Sediment Trap Symbol
1630.04	Stilling Basin	Stilling Basin Symbol
1630.06	Special Stilling Basin	Special Stilling Basin Symbol
	Rock Inlet Sediment Trap:	
1632.01	Type A	A
1632.02	Type B	B
1632.03	Type C	C
	Skimmer Basin	Skimmer Basin Symbol
	Tiered Skimmer Basin	Tiered Skimmer Basin Symbol
	Infiltration Basin	Infiltration Basin Symbol

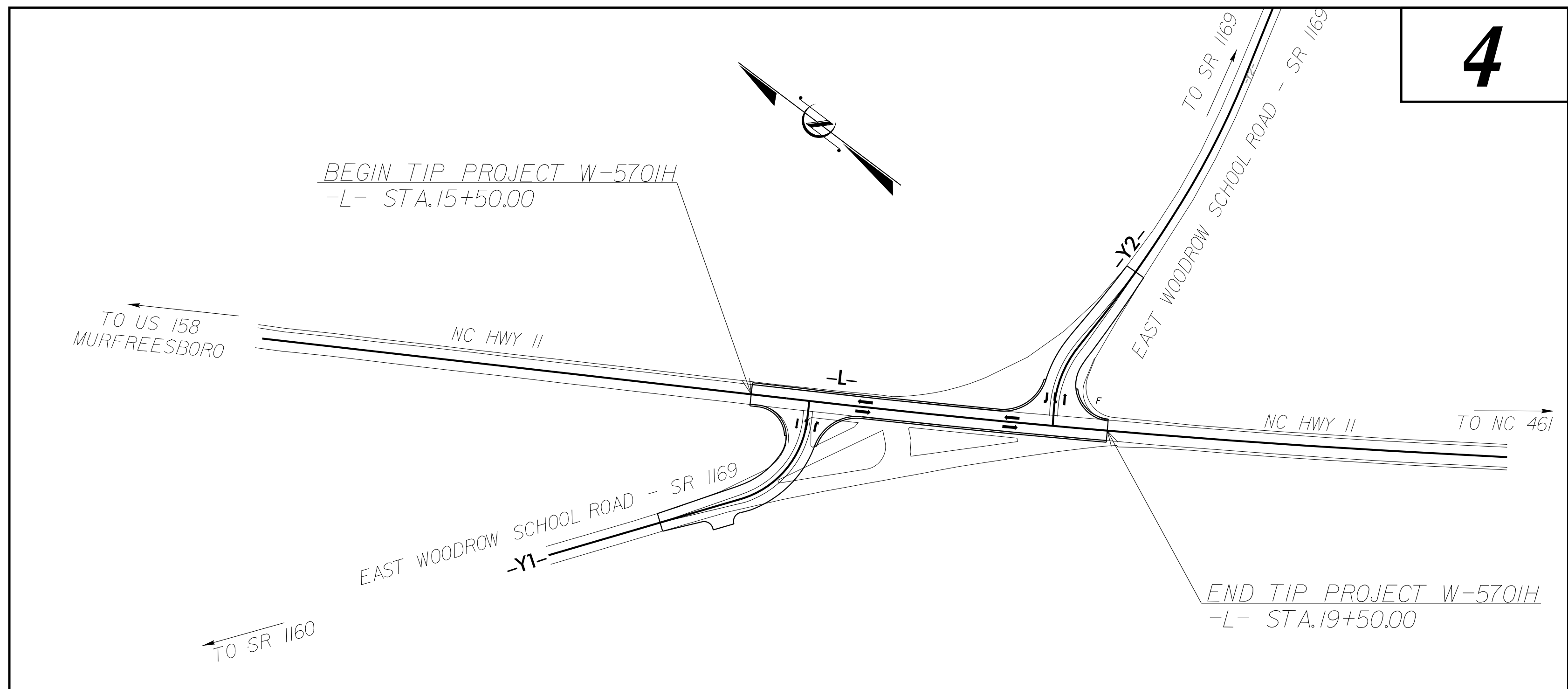

**THIS PROJECT CONTAINS  
EROSION CONTROL PLANS  
FOR CLEARING AND  
GRUBBING PHASE OF  
CONSTRUCTION.**

**CONTRACT:**

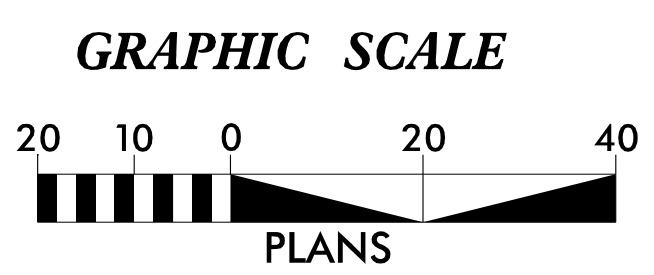

THESE EROSION AND SEDIMENT CONTROL PLANS COMPLY WITH THE APPLICABLE REGULATIONS SET FORTH BY THE NCG-010000 GENERAL CONSTRUCTION PERMIT EFFECTIVE APRIL 1, 2019 AND ISSUED BY THE NORTH CAROLINA DEPARTMENT OF ENVIRONMENTAL QUALITY DIVISION OF WATER RESOURCES.

**V&M**  
Vaughn & Melton  
Consulting Engineers

Asheville, North Carolina  
828-253-2796

Boone, NC 828-355-9933  
Tri-Cities, TN 423-467-9800  
Knoxville, TN 865-546-5600  
Spartanburg, SC 864-574-4775  
Charleston, SC 843-974-5650  
Morganton, NC 828-253-2796  
Charlotte, NC 704-267-0888  
Atlanta, GA 770-621-3590

Copyright © 2006 Vaughn & Melton, Inc. All Rights Reserved.

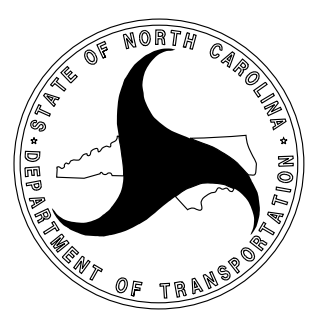

Prepared in the Office of:  
**Vaughn & Melton  
Consulting Engineers**

1318-F Patton Avenue  
Asheville, NC 28806

**2018 STANDARD SPECIFICATIONS**

Prepared by:  
COREY NAPIER 4098  
NAME LEVEL III CERTIFICATION NO.

Roadway Standard Drawings

The following roadway english standards as appear in "Roadway Standard Drawings"- Roadway Design Unit - N. C. Department of Transportation - Raleigh, N. C., dated January 2018 and the latest revision thereto are applicable to this project and by reference hereby are considered a part of these plans.

1604.01 Railroad Erosion Control Detail	1632.01 Rock Inlet Sediment Trap Type A
1605.01 Temporary Silt Fence	1632.02 Rock Inlet Sediment Trap Type B
1606.01 Special Sediment Control Fence	1632.03 Rock Inlet Sediment Trap Type C
1607.01 Gravel Construction Entrance	1633.01 Temporary Rock Silt Check Type A
1622.01 Temporary Berms and Slope Drains	1633.02 Temporary Rock Silt Check Type B
1630.01 Riser Basin	1634.01 Temporary Rock Sediment Dam Type A
1630.02 Silt Basin Type B	1634.02 Temporary Rock Sediment Dam Type B
1630.03 Temporary Silt Ditch	1635.01 Rock Pipe Inlet Sediment Trap Type A
1630.04 Stilling Basin	1635.02 Rock Pipe Inlet Sediment Trap Type B
1630.05 Temporary Diversion	1640.01 Coir Fiber Baffle
1630.06 Special Stilling Basin	1640.01 Coir Fiber Baffle
1631.01 Matting Installation	1645.01 Temporary Stream Crossing

11/28/2022 11:08:57 AM  
...W-5701H\_Fcy\_EC\_1.dgn  
User:RSanchez



PROJECT REFERENCE NO. W-5701H	SHEET NO. EC-2
RW SHEET NO.	
ROADWAY DESIGN ENGINEER	HYDRAULICS ENGINEER

# COIR FIBER WATTLE WITH POLYACRYLAMIDE (PAM) DETAIL

**NOTES:**

USE MINIMUM 12 IN. DIAMETER COIR FIBER (COCONUT FIBER) WATTLE.

USE 2 FT. WOODEN STAKES WITH A 2 IN. BY 2 IN. NOMINAL CROSS SECTION.

ONLY INSTALL WATTLE(S) TO A HEIGHT IN DITCH SO FLOW WILL NOT WASH AROUND WATTLE AND SCOUR DITCH SLOPES AND AS DIRECTED.

INSTALL A MINIMUM OF 2 UPSLOPE STAKES AND 4 DOWNSLOPE STAKES AT AN ANGLE TO WEDGE WATTLE TO BOTTOM OF DITCH.

PROVIDE STAPLES MADE OF 0.125 IN. DIAMETER STEEL WIRE FORMED INTO A U SHAPE NOT LESS THAN 12" IN LENGTH.

INSTALL STAPLES APPROXIMATELY EVERY 1 LINEAR FOOT ON BOTH SIDES OF WATTLE AND AT EACH END TO SECURE IT TO THE SOIL.

INSTALL MATTING IN ACCORDANCE WITH SECTION 1631 OF THE STANDARD SPECIFICATIONS.

PRIOR TO POLYACRYLAMIDE (PAM) APPLICATION, OBTAIN A SOIL SAMPLE FROM PROJECT LOCATION, AND FROM OFFSITE MATERIAL, AND ANALYZE FOR APPROPRIATE PAM FLOCCULANT TO BE APPLIED TO EACH WATTLE.

INITIALLY APPLY 2 OUNCES OF ANIONIC OR NEUTRALLY CHARGED PAM OVER WATTLE WHERE WATER WILL FLOW AND 1 OUNCE OF PAM ON EACH SIDE OF WATTLE. REAPPLY PAM AFTER EVERY RAINFALL EVENT THAT IS EQUAL TO OR EXCEEDS 0.50 IN.

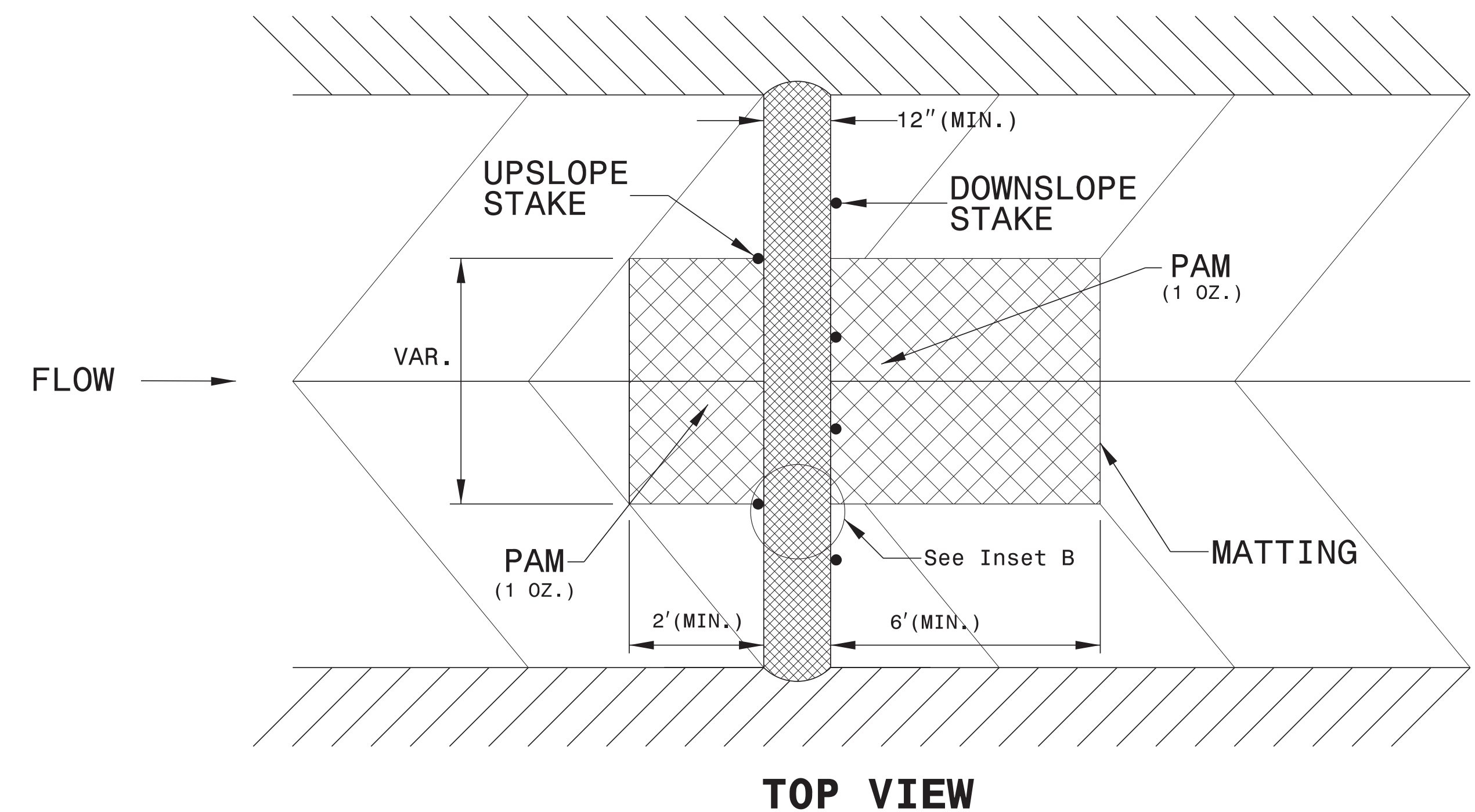
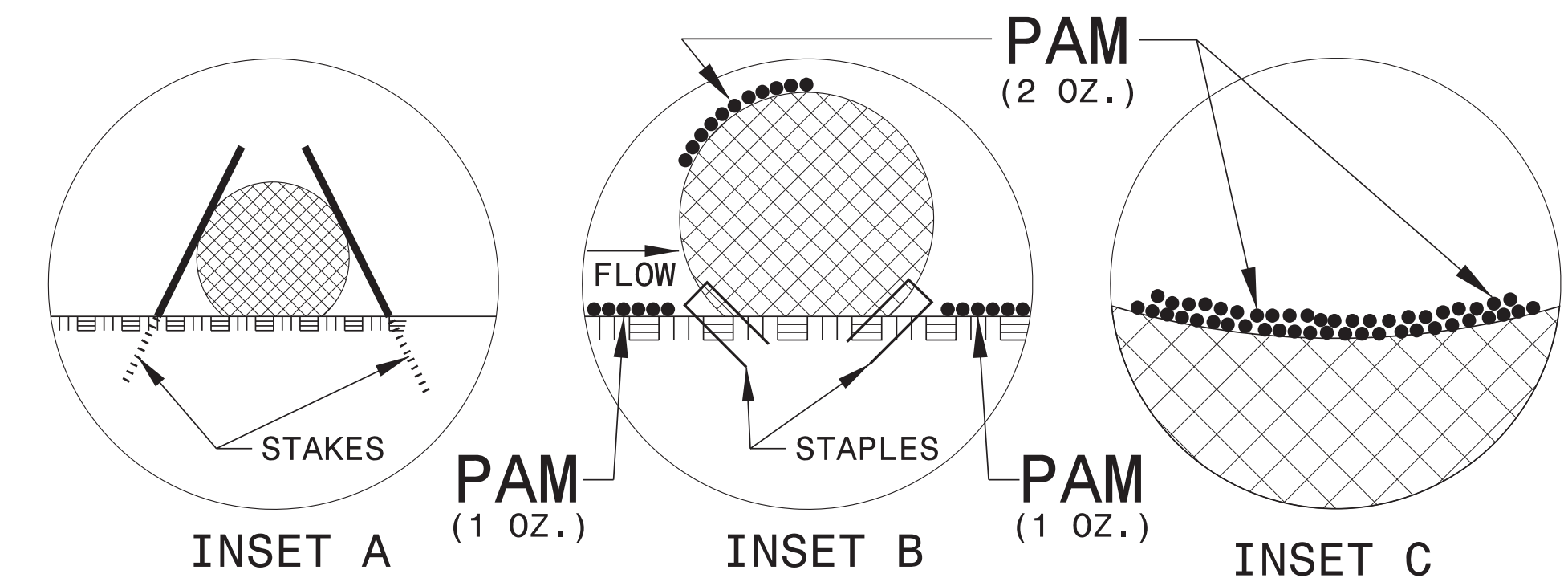
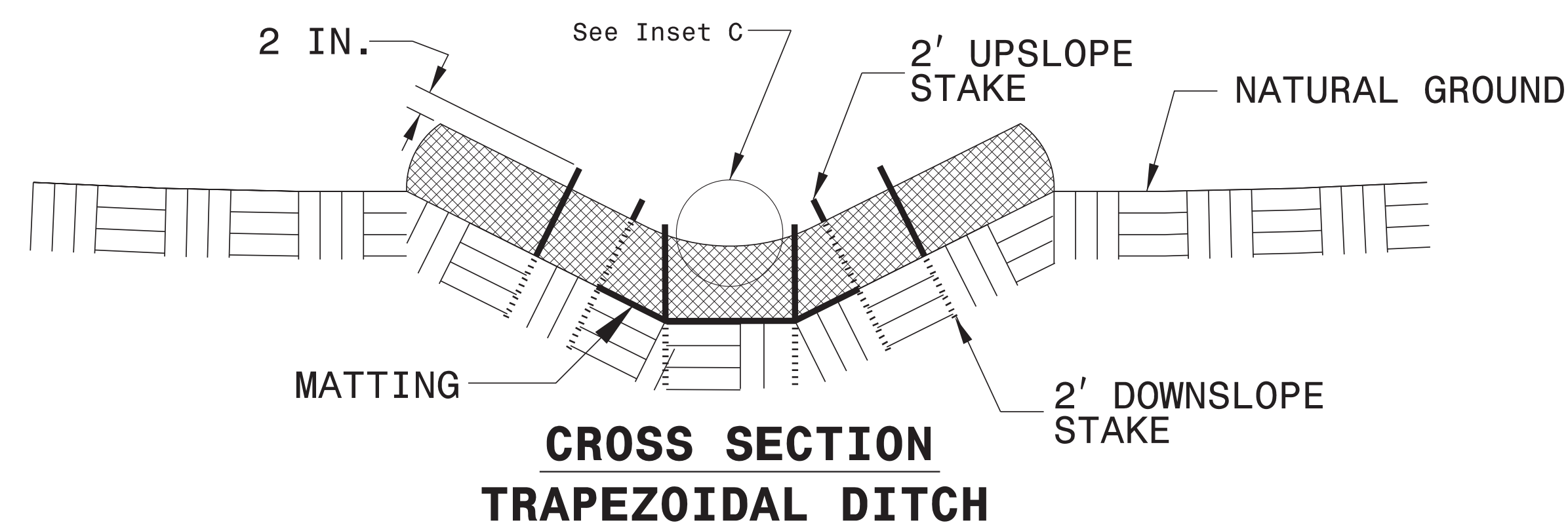
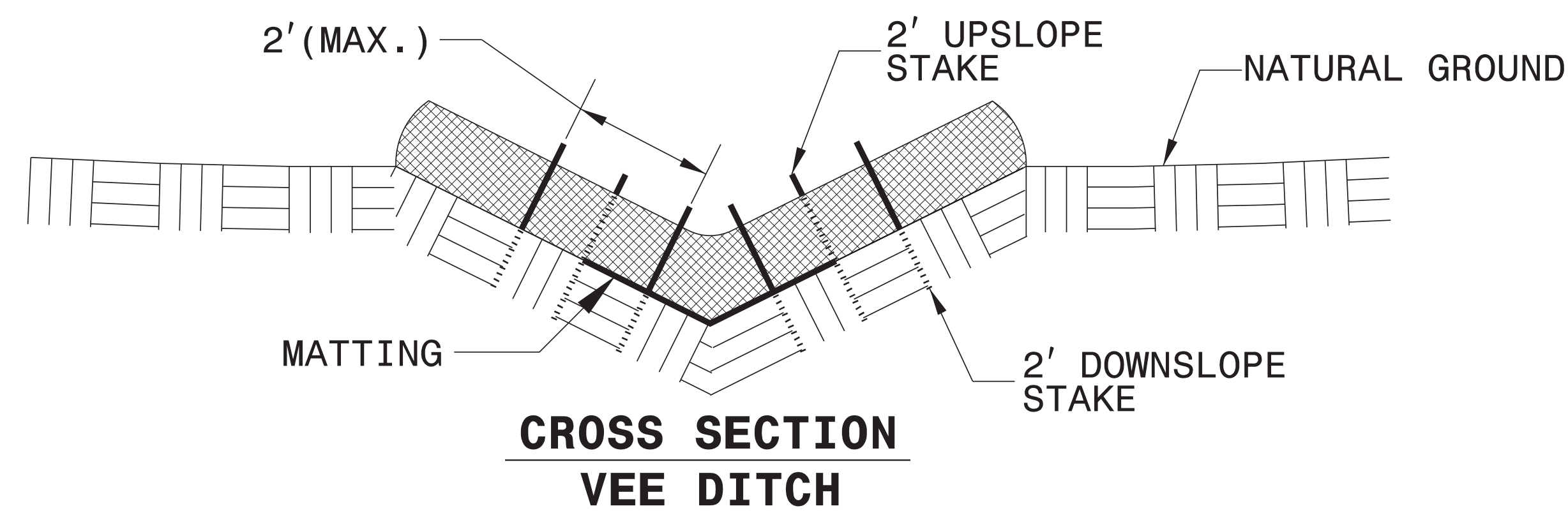
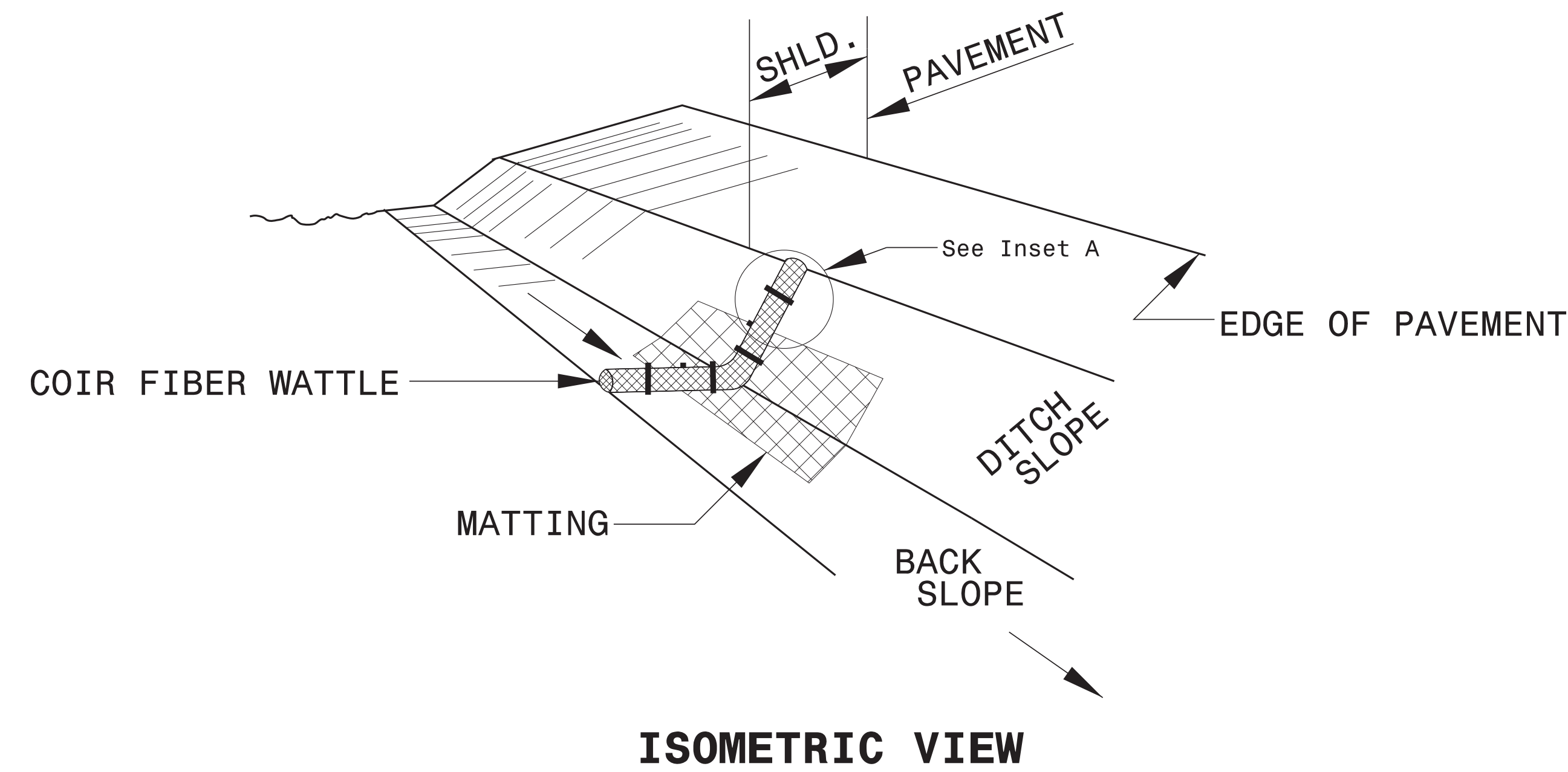



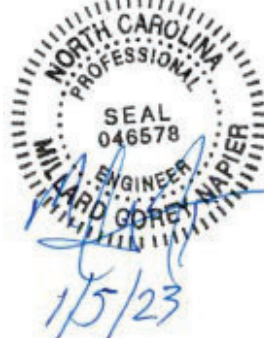

PROJECT REFERENCE NO. <i>W-5701H</i>	SHEET NO. <i>EC-3A</i>
RW SHEET NO.	
ROADWAY DESIGN ENGINEER	HYDRAULICS ENGINEER
	

STATE OF NORTH CAROLINA  
DIVISION OF HIGHWAYS

***SOIL STABILIZATION TIMEFRAMES***

<i>SITE DESCRIPTION</i>	<i>STABILIZATION TIME</i>	<i>TIMEFRAME EXCEPTIONS</i>
PERIMETER DIKES, SWALES, DITCHES AND SLOPES	7 DAYS	NONE
HIGH QUALITY WATER (HQW) ZONES	7 DAYS	NONE
SLOPES STEEPER THAN 3:1	7 DAYS	IF SLOPES ARE 10' OR LESS IN LENGTH AND ARE NOT STEEPER THAN 2:1, 14 DAYS ARE ALLOWED.
SLOPES 3:1 OR FLATTER	14 DAYS	7 DAYS FOR SLOPES GREATER THAN 50' IN LENGTH.
ALL OTHER AREAS WITH SLOPES FLATTER THAN 4:1	14 DAYS	NONE, EXCEPT FOR PERIMETERS AND HQW ZONES.



PROJECT REFERENCE NO. W-570IH	SHEET NO. EC-4/CONST.4
RW SHEET NO.	
ROADWAY DESIGN ENGINEER	HYDRAULICS ENGINEER

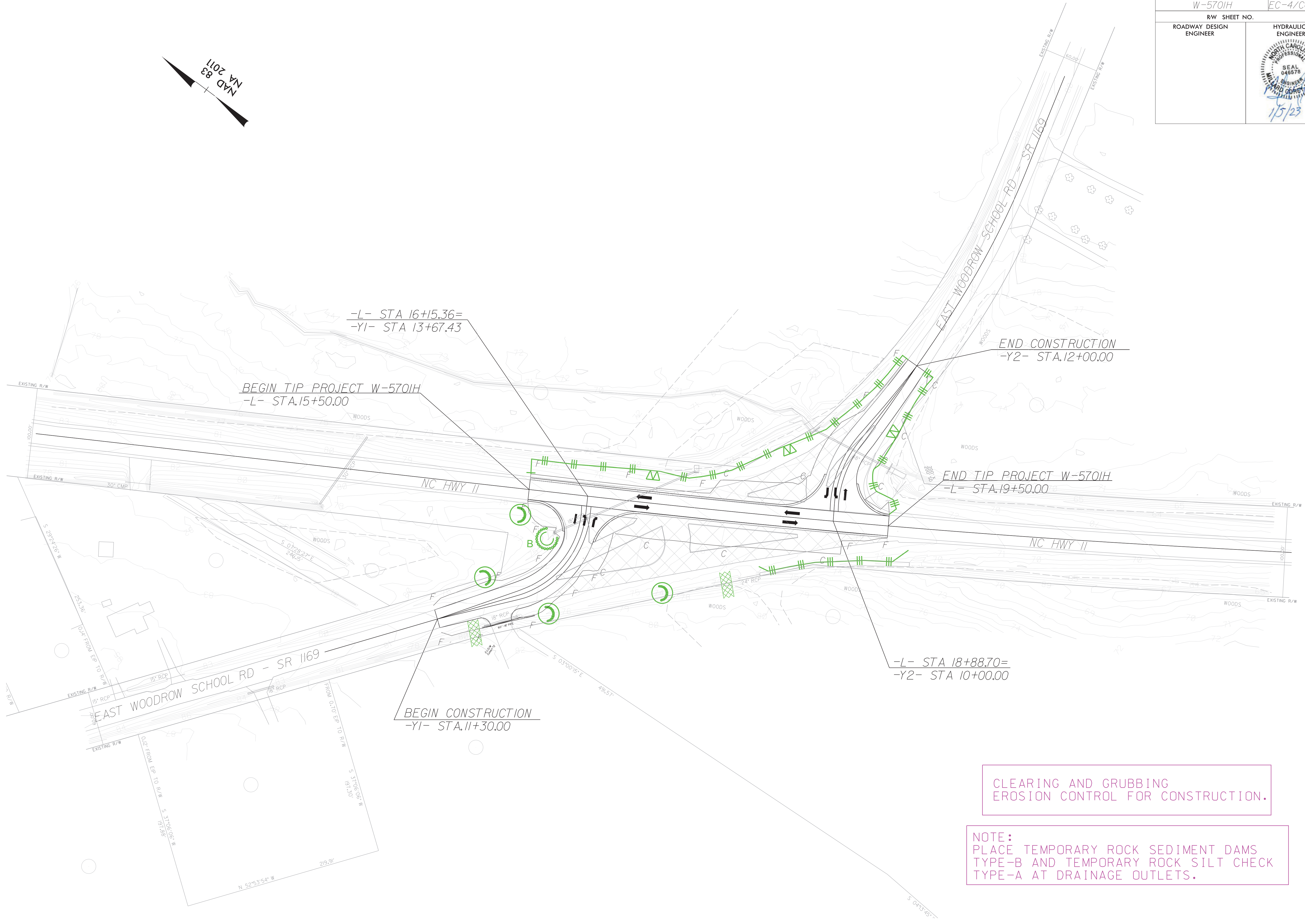
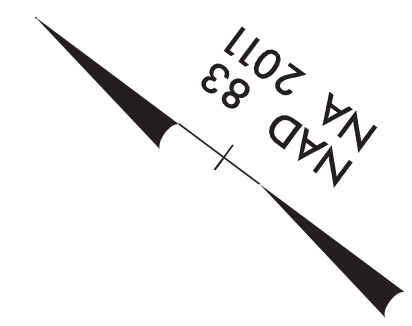

CLEARING AND GRUBBING  
EROSION CONTROL FOR CONSTRUCTION.

NOTE:  
PLACE TEMPORARY ROCK SEDIMENT DAMS  
TYPE-B AND TEMPORARY ROCK SILT CHECK  
TYPE-A AT DRAINAGE OUTLETS.

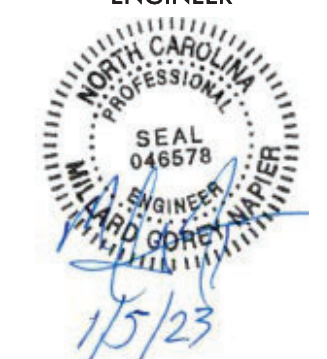

PROJECT REFERENCE NO.	SHEET NO.
W-570IH	EC-5/CONST.4
RW SHEET NO.	HYDRAULICS ENGINEER
ROADWAY DESIGN ENGINEER	

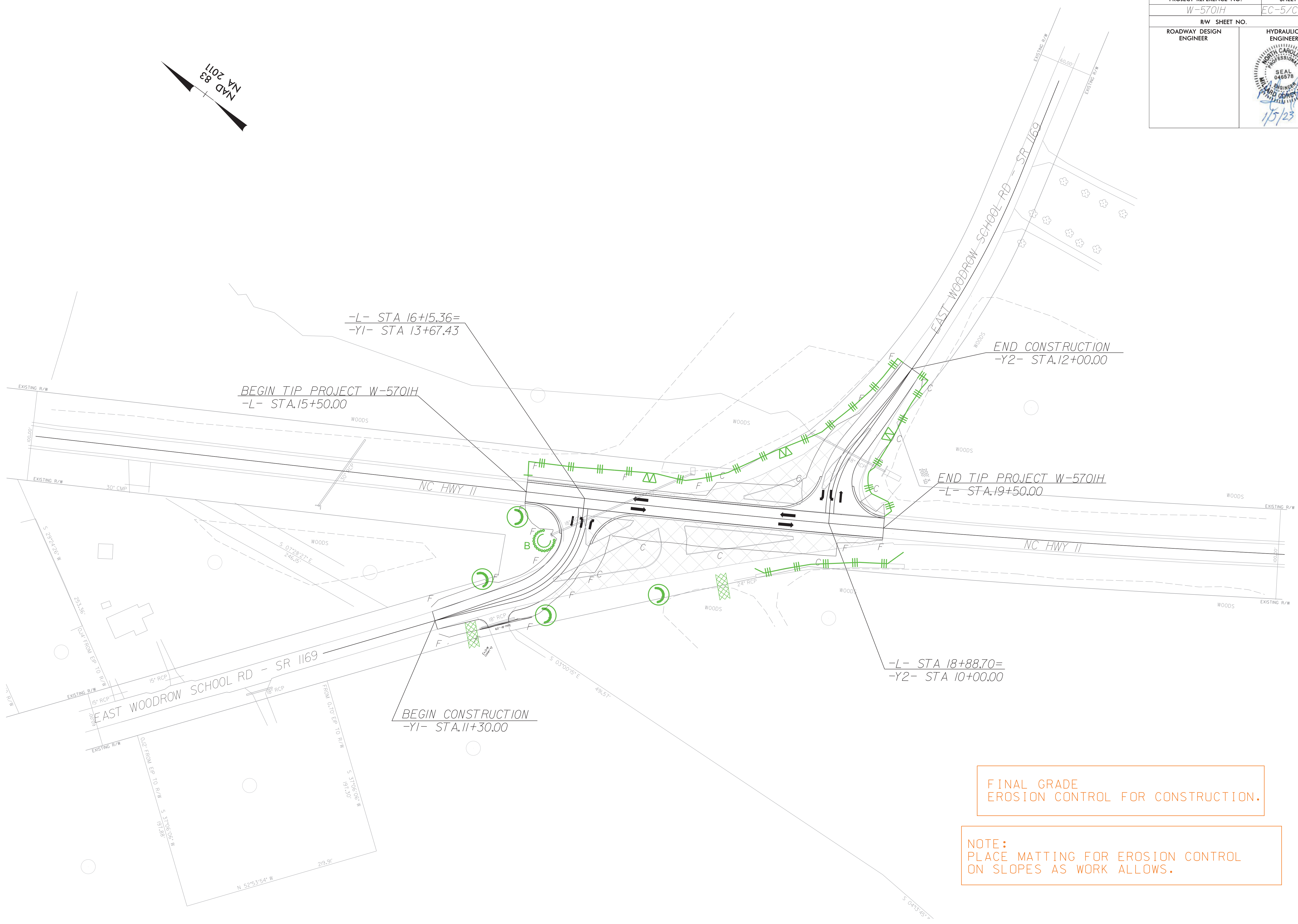
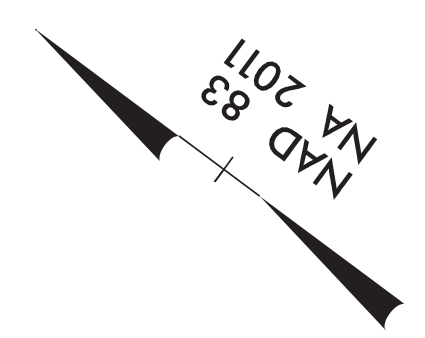

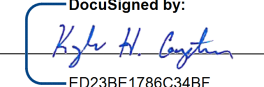
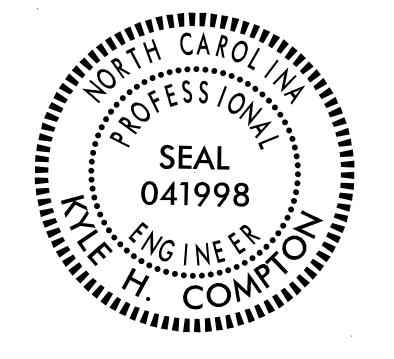
TIP NO. W-5701H	SHEET NO. SIGN-1
APPROVED:  DATE: 1/10/2023	
SEAL 	
DOCUMENT NOT CONSIDERED FINAL UNLESS ALL SIGNATURES COMPLETED	

**STATE OF NORTH CAROLINA  
DEPARTMENT OF TRANSPORTATION**

**SIGNING PLAN  
HERTFORD COUNTY**

**LOCATION: NC-11 INTERSECTION AT SR 1169 (E WOODROW SCHOOL RD)**

**T.I.P.: W-5701H**

**ROADWAY STANDARD DRAWING**

THE FOLLOWING ROADWAY STANDARDS AS APPEAR IN "ROADWAY STANDARD DRAWINGS" - PROJECT SERVICES UNIT - N.C. DEPARTMENT OF TRANSPORTATION - RALEIGH, N.C., DATED JANUARY 2018 ARE APPLICABLE TO THIS PROJECT AND BY REFERENCE HEREBY ARE CONSIDERED A PART OF THESE PLANS:

STD. NO.	TITLE
903.10	GROUND MOUNTED SIGN SUPPORTS
904.10	ORIENTATION OF GROUND MOUNTED SIGN
904.50	MOUNTING OF TYPE 'D', 'E' AND 'F' SIGNS ON 'U' CHANNEL POST

**GENERAL NOTES**

- . SIGNS FURNISHED BY STATE.
- . IF REMOVAL OR RELOCATION OF SIGNS ON PRIVATE STREET (NON-STATE MAINTAINED) IS REQUIRED DUE TO CONSTRUCTION, THE CONTRACTOR SHALL INFORM THE ENGINEER. THE WORK WILL BE COMPLETED BY OTHERS.
- . WHEN NOT STATIONED OR DIMENSIONED ON PLANS, ALL 'E' AND 'F' SIGNS SHALL BE FIELD LOCATED BY THE ENGINEER
- . ALL EXISTING SIGNS ON "U" CHANNEL POST WITHIN THE PROJECT LIMITS SHALL BE REMOVED AND DISPOSED OF UNLESS OTHERWISE NOTED ON PLANS.
- . WHEN EXISTING SIGNS ARE REMOVED AND INSTALLED ON NEW SUPPORTS, THE RE-ERECTION SHALL IMMEDIATELY FOLLOW THE REMOVAL.
- . THE BACKGROUND FOR TYPE E & F SIGNS SHALL BE TYPE C REFLECTIVE SHEETING.
- . SEE ROADWAY PLANS FOR GUARD RAIL DETAILS.

**SUMMARY OF QUANTITIES**

ITEM NO.	ITEM DESCRIPTION	QUANTITY	UNIT
4072000000	SUPPORT, 3-LB. STEEL U-CHANNEL	44	LF.
4102000000	SIGN ERECTION, TYPE E	4	EA.
4116100000	SIGN ERECTION, RELOCATE SIGN TYPE E (GROUND MOUNTED)	2	EA.
4155000000	DISPOSAL OF SIGN SYSTEM, U-CHANNEL	8	EA.

**INDEX**

SHEET NO.	DESCRIPTION
SIGN-1	TITLE SHEET
SIGN-2	TYPE E SIGNS
SIGN-3 THRU SIGN-4	SIGNING DETAIL

**CONTRACT:**

1/2/2022 1:23:12 PM  
V:\NC\Transportation\031737-14 NC11 Hertford\Signing and Delineation\W-5701H\_sign\_TSH.dgn  
User:ram1tzp0a7r1ck

<b>PLAN PREPARED BY: Vaughn &amp; Melton Engineering</b>		 <p>Asheville, North Carolina 828-293-2796</p>	<input type="checkbox"/> Raleigh, NC 919-977-9455 <input type="checkbox"/> Tri-Cities, TN 423-467-8401 <input type="checkbox"/> Charleston, SC 843-914-9950 <input type="checkbox"/> Spartanburg, SC 864-574-4775	<input type="checkbox"/> Charlotte, NC 704-357-0488 <input type="checkbox"/> Tri-Cities, TN 423-467-8401 <input type="checkbox"/> Milledgeboro, KY 606-248-6600 <input type="checkbox"/> Atlanta, GA 770-621-3509	<input type="checkbox"/> Boone, NC 828-355-9933 <input type="checkbox"/> Knoxville, TN 865-546-5800
<u>JOHN LANSFORD, P.E.</u> <u>JARED PHILPOT</u>	PROJECT ENGINEER PROJECT DESIGN ENGINEER		<small>Copyright © 2006 Vaughn &amp; Melton, Inc. All Rights Reserved</small>		

5/14/99

401 QUANTITY REQ'D 2

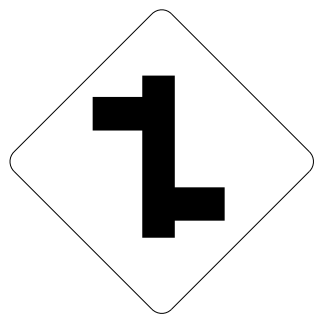

30" x 30"  
W2-7R

ONE "U" POST PER SIGN

TIP NO. SHEET NO.  
W-5701H SIGN-2

DocuSigned by:  
APPROVED: *Rylee H. Gough*  
DATE: 1/10/2023

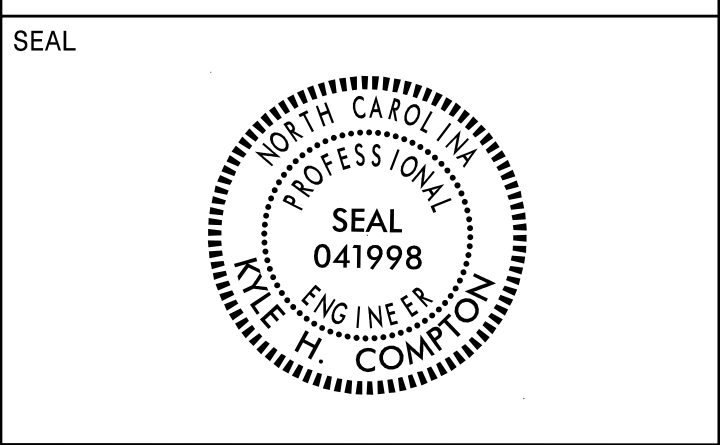

DOCUMENT NOT CONSIDERED FINAL  
UNLESS ALL SIGNATURES COMPLETED

TYPE 'E' SIGNS

I:\2022\12459-PM\Signing and Delineation\W-5701H-sign-Esigns.dgn  
3/17/2022 12:45:59 PM  
User: rbg



APPROVED: *Ryan H. Coughlin*  
DATE: 1/10/2023  
E023BE1786C34BF

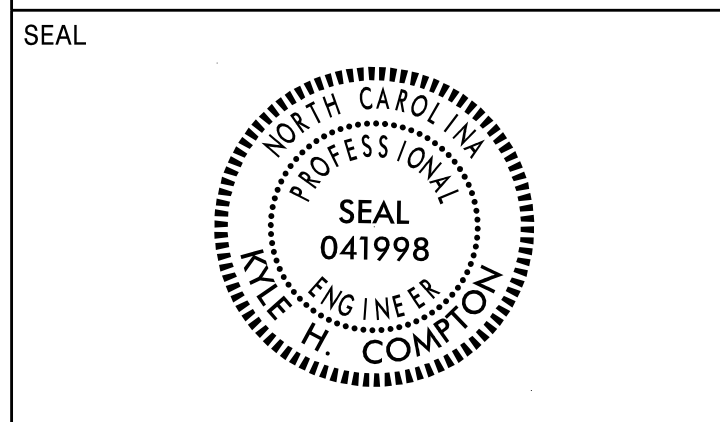

DOCUMENT NOT CONSIDERED FINAL  
UNLESS ALL SIGNATURES COMPLETED

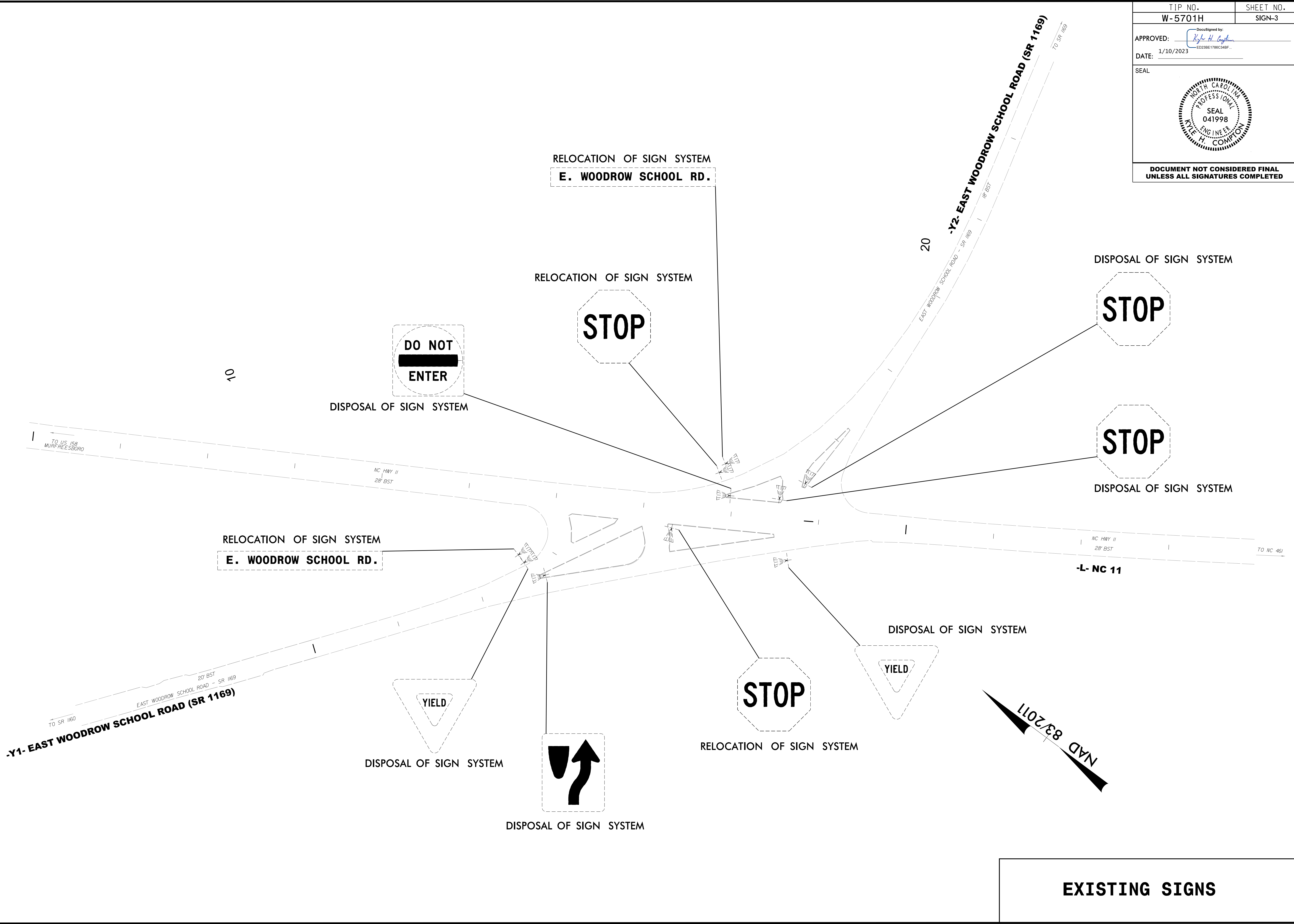

1/2/2022 1:27:33 PM  
V:\NC\Transportation\031737-14 NC11 Herford\Signing and Delineation\W-5701H-sign-exist-pahdgn  
User: tam1122@itc.com

**EXISTING SIGNS**

TIP NO. <b>W-5701H</b>	SHEET NO. SIGN-4
APPROVED: <i>Kyle H. Coyle</i> EDD3BE1786C348F	
DATE: 1/10/2023	
SEAL	
	
<b>DOCUMENT NOT CONSIDERED FINAL UNLESS ALL SIGNATURES COMPLETED</b>	

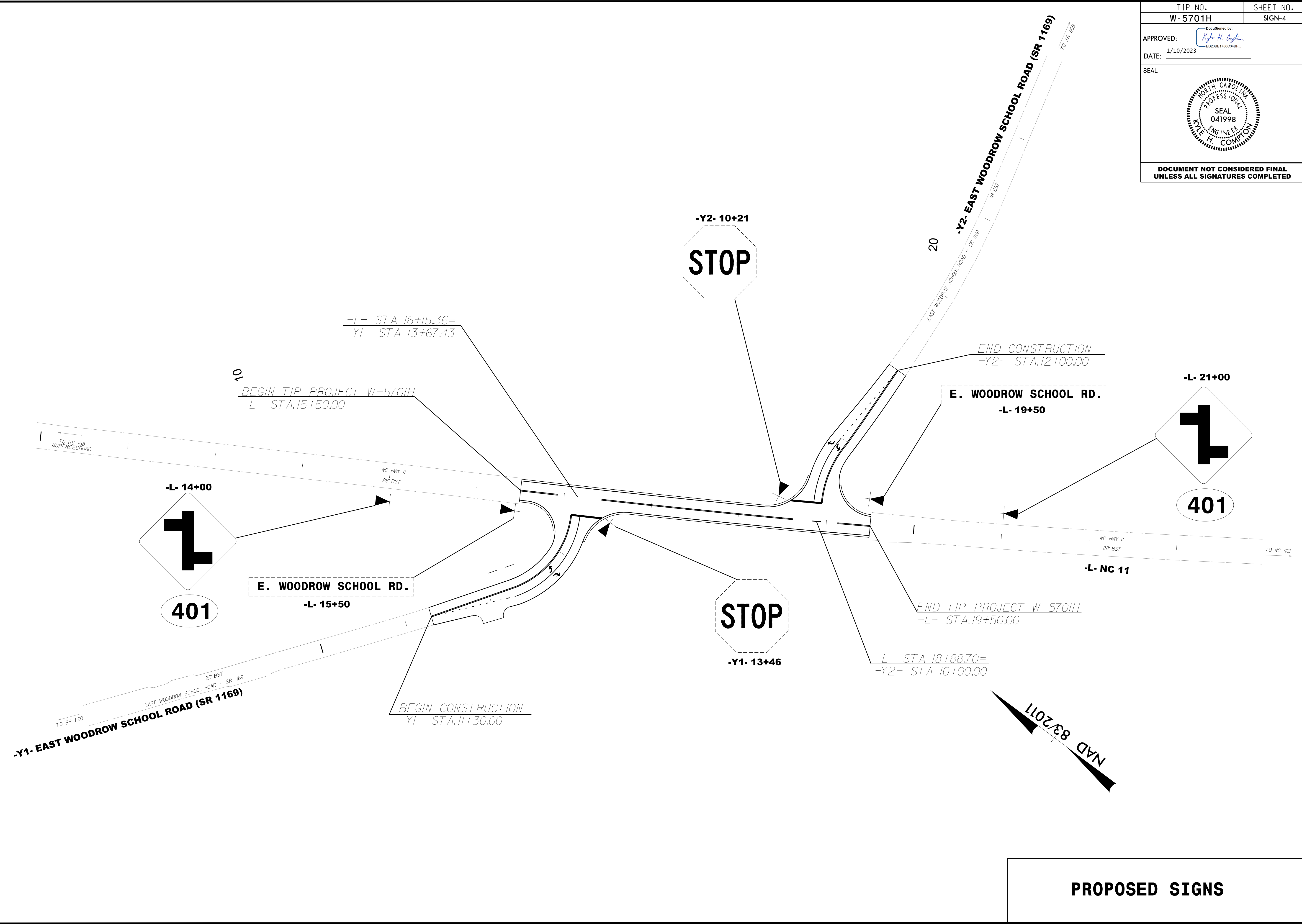

1/2/2022 1:59:00 PM  
 V:\NC\Transportation\031737-14 NC11 Herford\Signing and Delineation\W-5701H-sign-PROP\_psh.dgn  
 User: tam1122@tdc

**PROPOSED SIGNS**

# *W-5701H*

## **CROSS SECTION INDEX**

<u>DESCRIPTION</u>	<u>SHEET NO.</u>
CROSS SECTION SUMMARY	X-1A
-Y1-	X-1 TO X-3
-Y2-	X-4 TO X-7



STATE OF NORTH CAROLINA  
HERTFORD COUNTY

DOCUMENT NOT CONSIDERED FINAL  
UNLESS ALL SIGNATURES COMPLETED

W-5701H  
X X-1A

**CROSS SECTION SUMMARY**  
IN CUBIC YARDS

SURVEY LINE	STATION	UNCLASSIFIED EXCAVATION	EMBT
-Y1-	11+30	0	0
-Y1-	11+50	4	2
-Y1-	12+00	7	9
-Y1-	12+50	6	8
-Y1-	13+00	19	4
-Y1-	13+50	27	0
-Y1-	13+67.43	4	0
-Y2-	10+00	0	0
-Y2-	10+25	65	0
-Y2-	10+50	110	0
-Y2-	10+75	84	0
-Y2-	11+00	67	0
-Y2-	11+25	44	0
-Y2-	11+50	22	0
-Y2-	11+75	12	0
-Y2-	12+00	5	0
-Y2-	12+25	0	0

NOTE: EMBANKMENT COLUMN DOES NOT INCLUDE BACKFILL FOR UNDERCUT.

Note: Approximate quantities only. Unclassified Excavation, Fine Grading, Clearing and Grubbing, and Removal of Existing Pavement will be paid for at the contract lump sum price for "Grading."

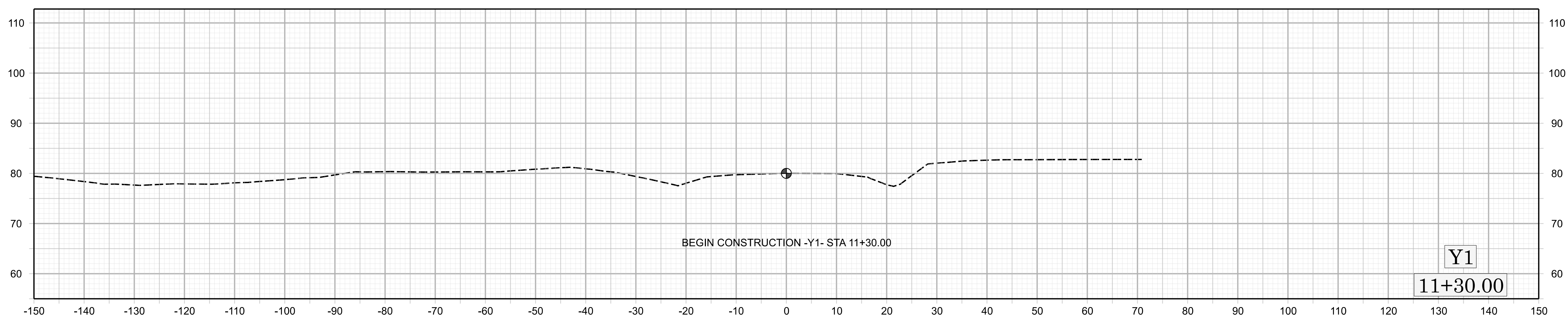
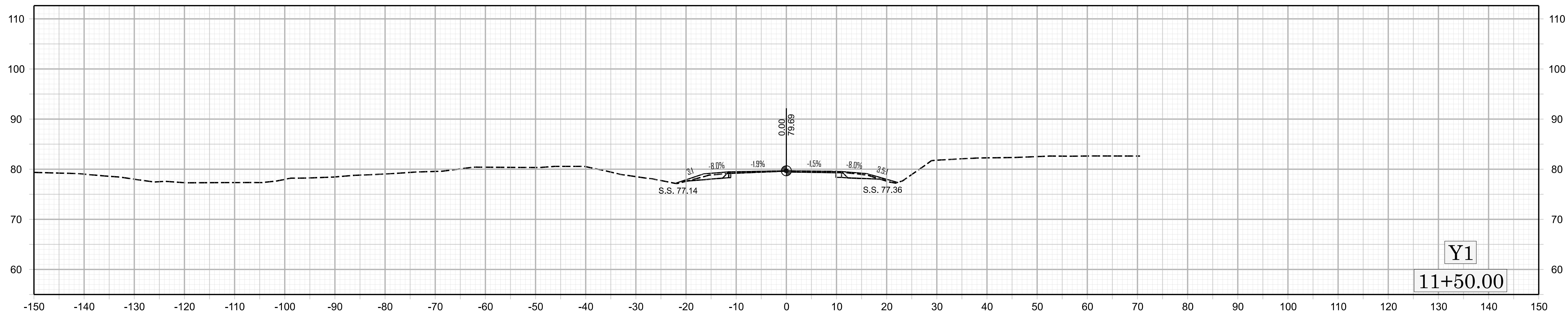
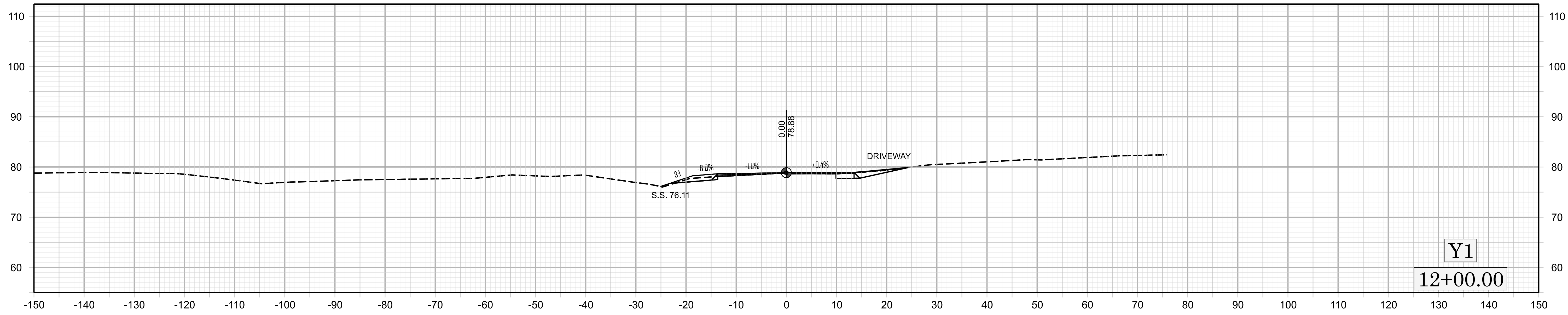

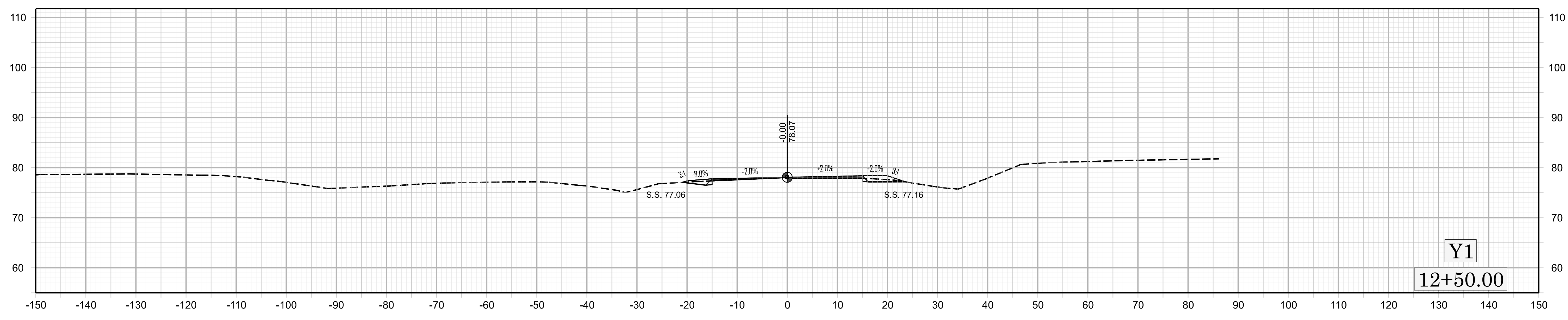
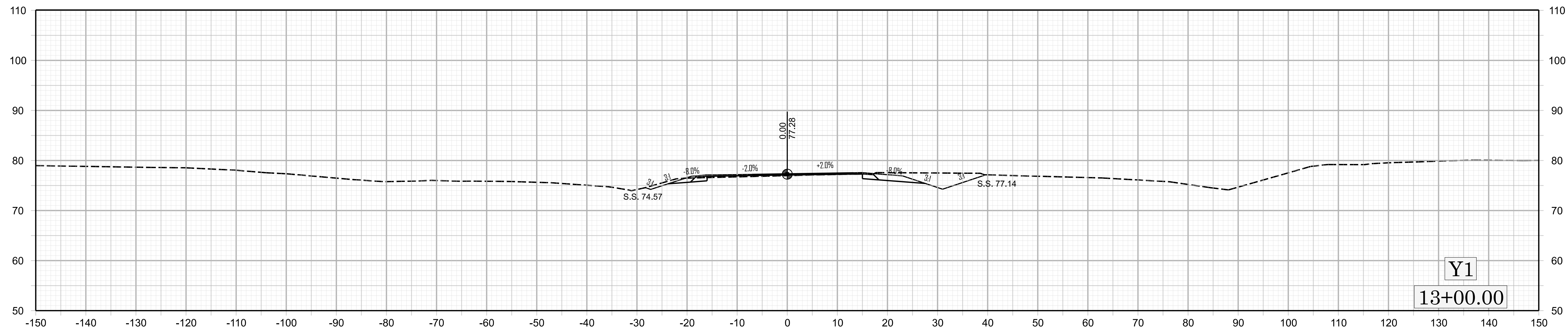
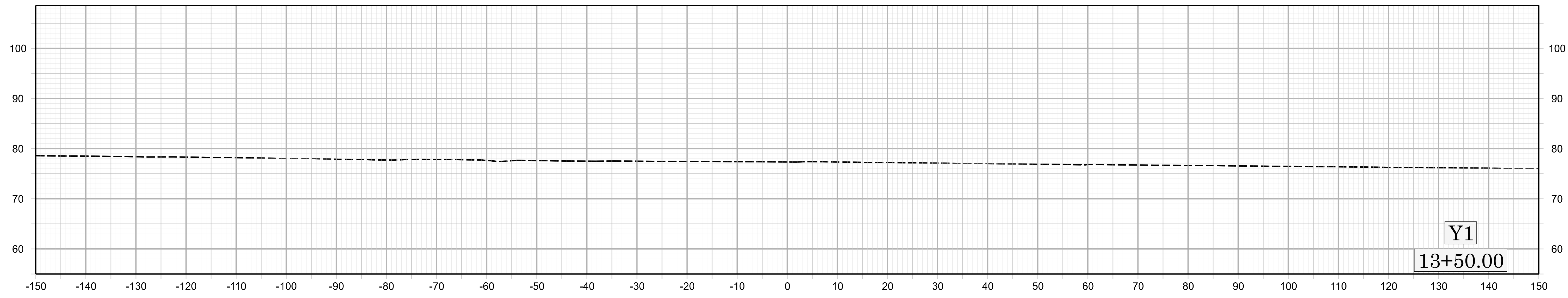



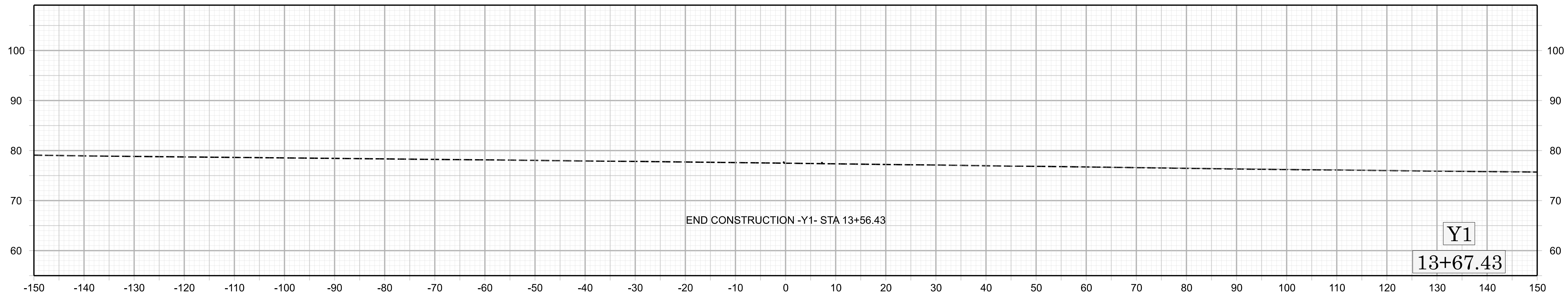
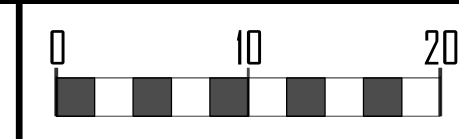

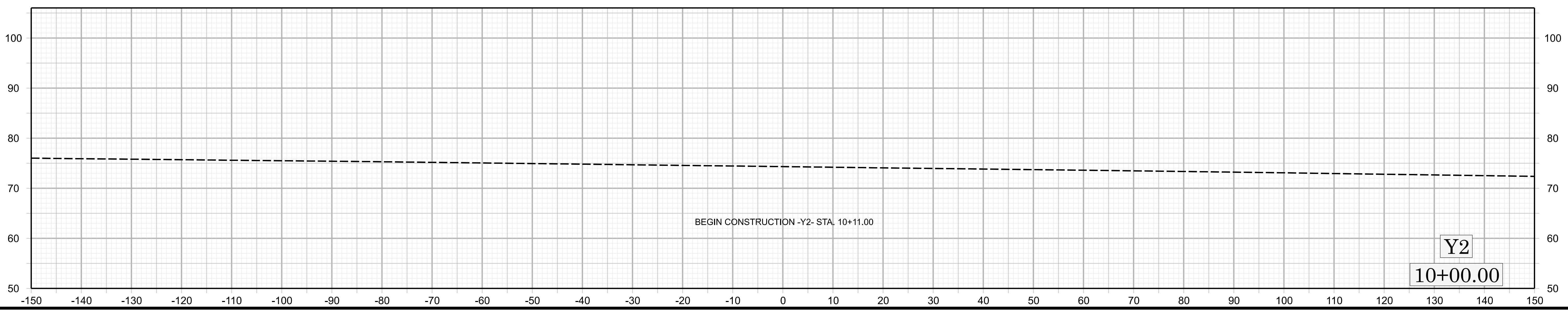
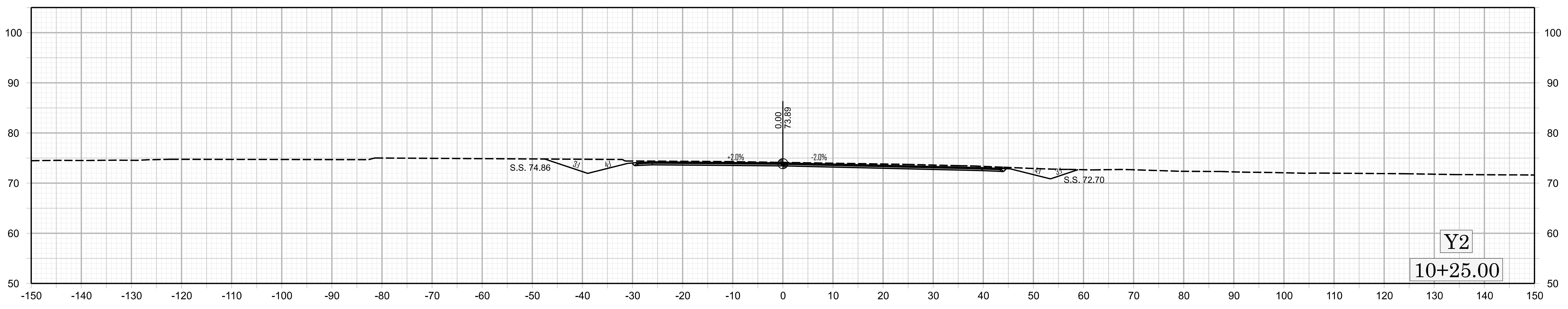
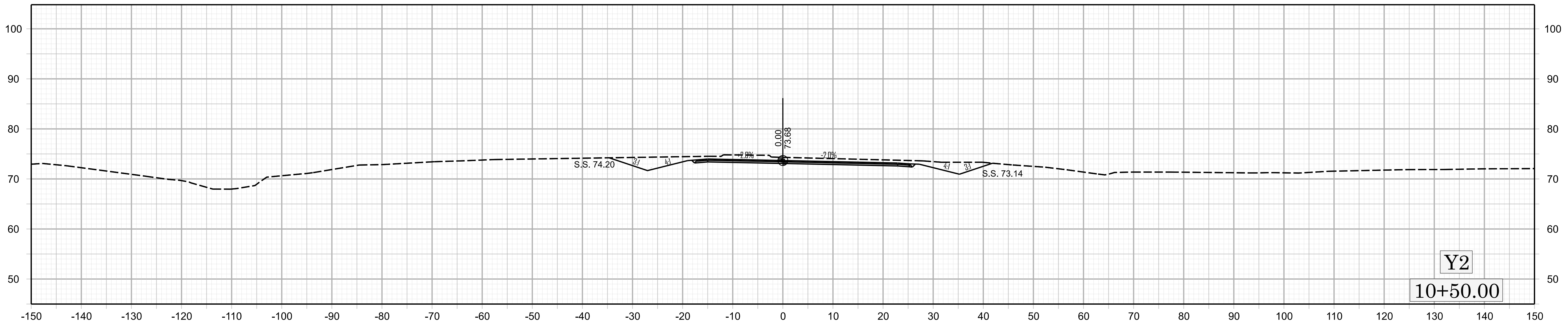

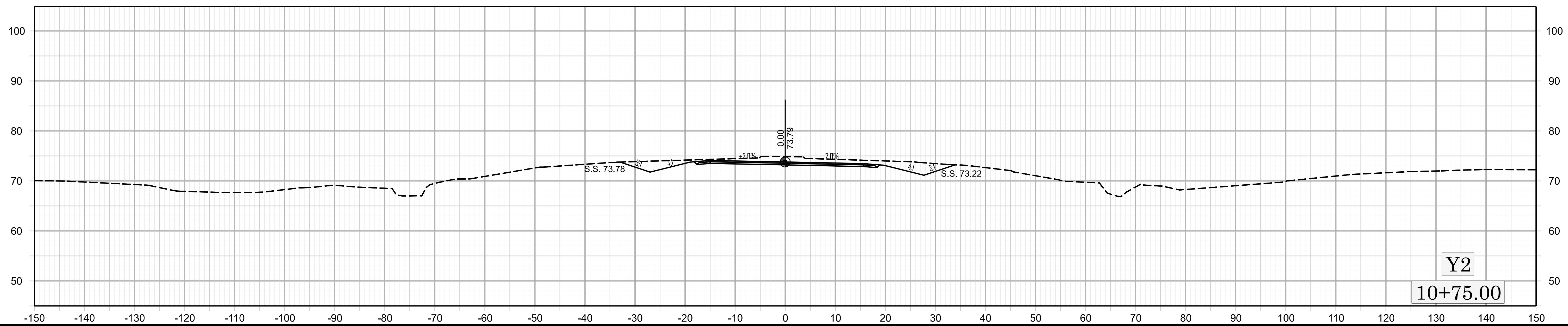
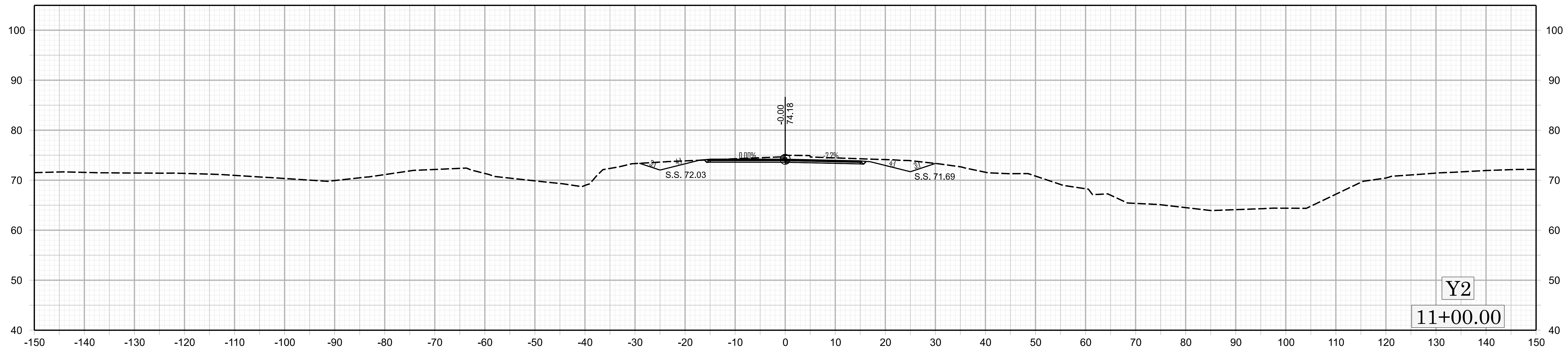
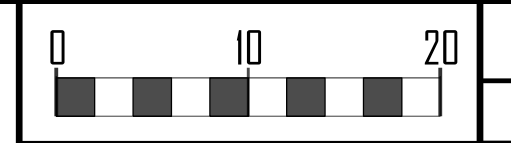



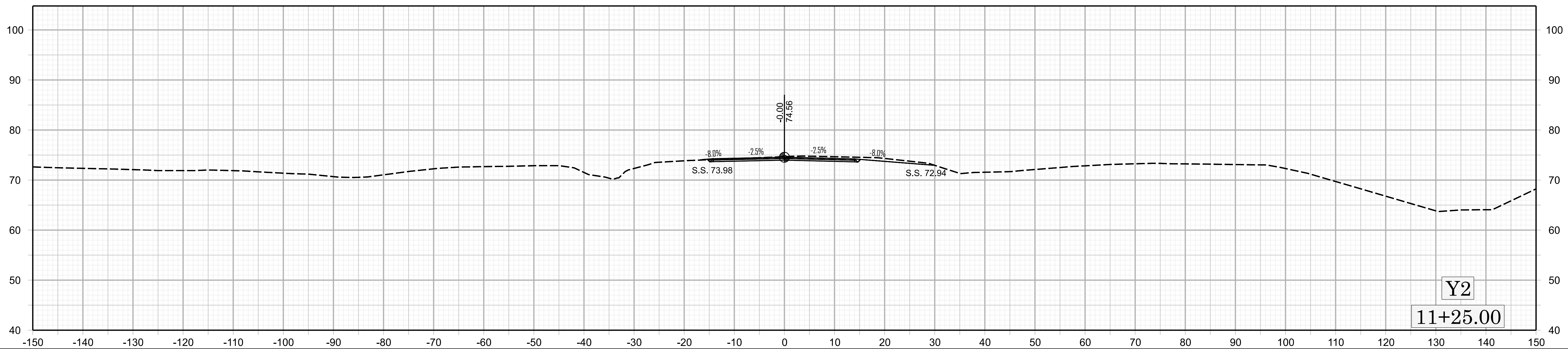
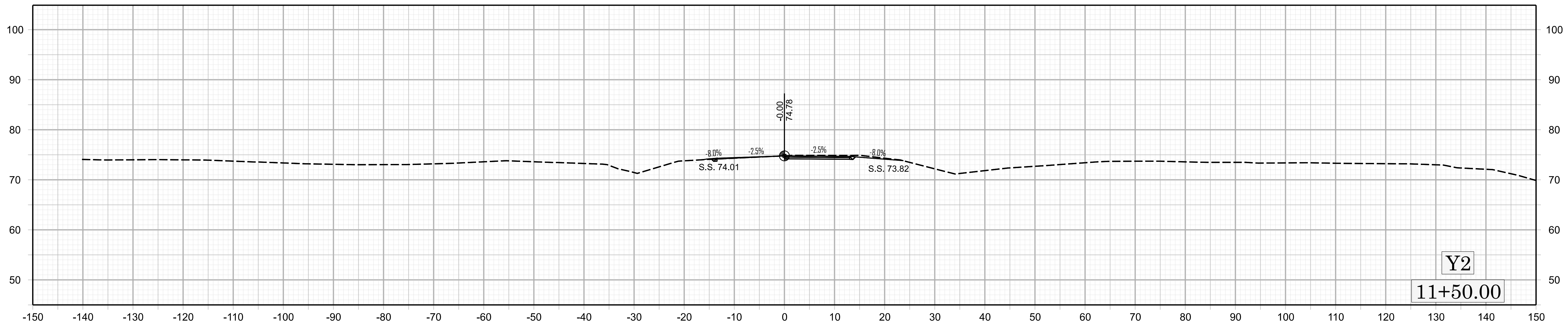
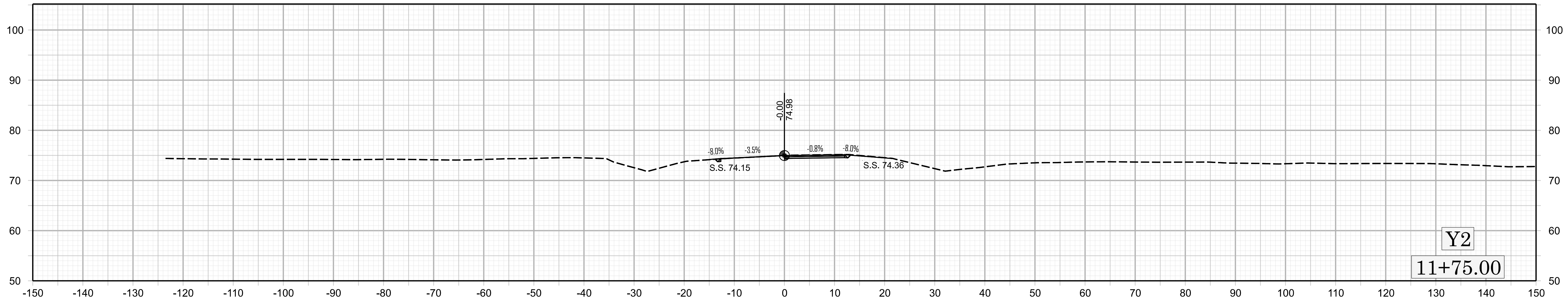
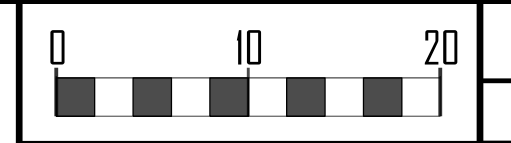

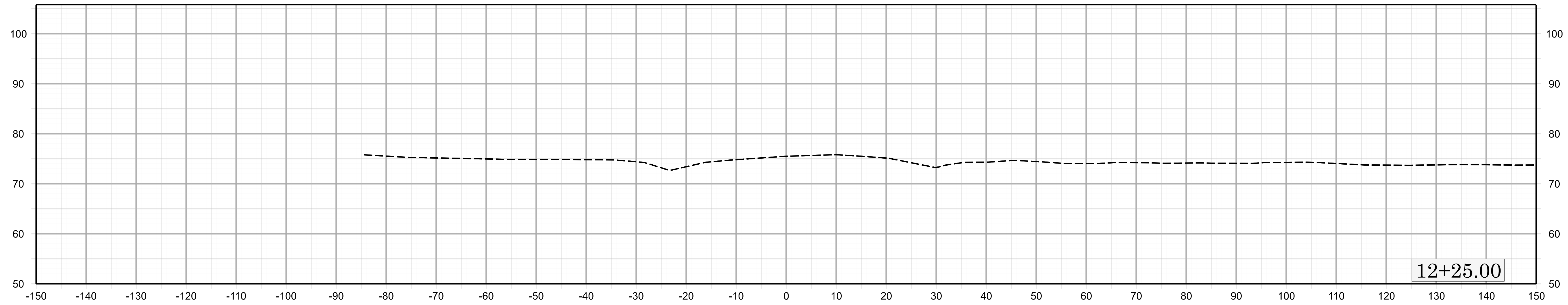
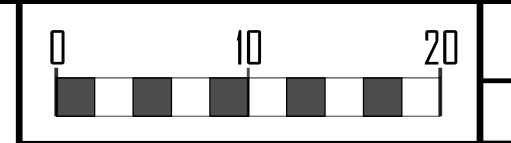

12+25.00

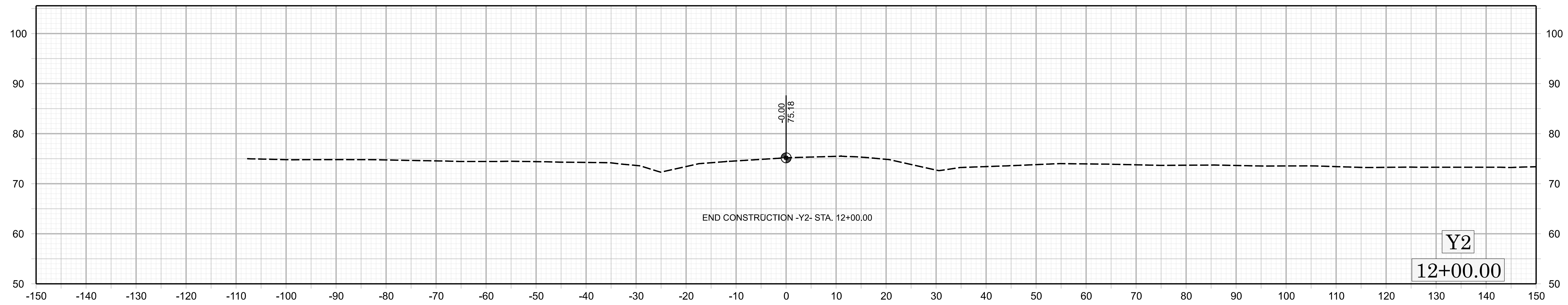

END CONSTRUCTION -Y2- STA. 12+00.00

75.18  
-0.00

Y2

12+00.00